2024

Konstrukcje oświetlenia drogowego

Constructions of road lighting



elmonter

Przykład oznaczenia słupa An example of a column marking

CN 5/3/60/W

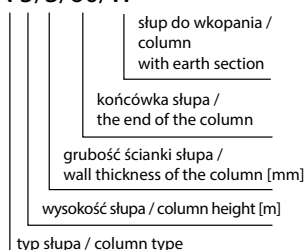

Przykład oznaczenia słupa An example of a column marking

SO 5/4/F160

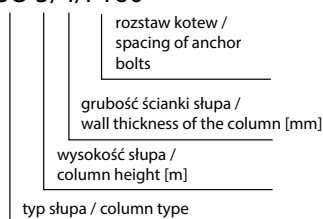

Przykład oznaczenia słupa An example of a column marking

SRN 5-2/60/F160

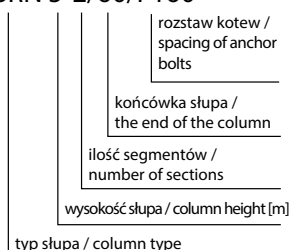



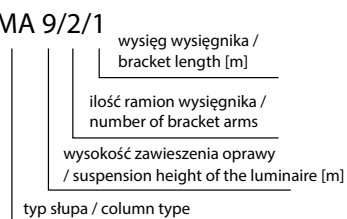

Przykład oznaczenia słupa z wysięgnikiem An example of marking a pole with a bracket

SIGMA 9/2/1

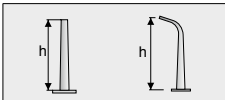
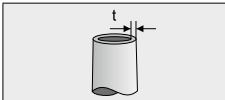
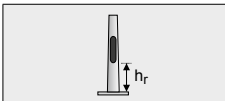
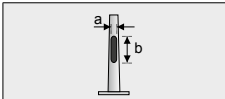
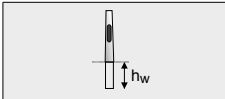
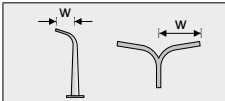
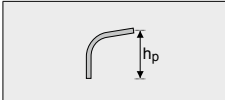
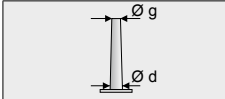

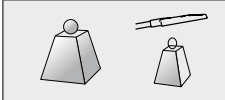
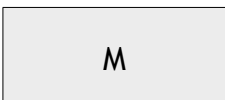
Oznaczenia użyte w tabelach / Symbols used in tables:

	wysokość słupa / słupa z wysięgnikiem <i>height of the column / height of the column with a bracket</i>
	grubość ścianki słupa <i>wall thickness of the column</i>
	odległość wnęki od podstawy słupa lub poziomu gruntu (dla słupów do wkopania) <i>the distance of the cavity door from the base of column or from ground (for column with earth section)</i>
	wymiary otworu wnęki <i>dimensions of the fuse box</i>
	głębokość wkopania słupa <i>the depth of digging the pole into the ground</i>
	długość wysięgnika od osi słupa <i>bracket's length from the pole's axle</i>
	wysokość wysięgnika <i>bracket height</i>
	średnica wierzchołka/podstawy słupa <i>diameter of the top / base of the column</i>
	fundament <i>foundation</i>
	waga / waga oprawy (opraw) <i>weight / weight of the luminaire (luminaires)</i>
	M moment obliczeniowy u podstawy <i>bending moment at the base</i>
	T siła tnąca u podstawy <i>shear force at the base</i>

Spis treści / Contents

Wstęp	3
Introduction	
Rodzaje słupów	4
Types of lighting poles	
Słupy oświetleniowe 3÷5 m	5
Lighting poles 3÷5 m	
Słupy oświetleniowe 6÷7 m	6
Lighting poles 6÷7 m	
Słupy oświetleniowe 8÷10 m	7
Lighting poles 8÷10 m	
Słupy oświetleniowe 11÷12 m	8
Lighting poles 11÷12 m	
Słupy z wysięgnikiem	9
Lighting poles with bracket	
Słupy z wysięgnikiem - BETA	10
Lighting poles with bracket - BETA	
Słupy z wysięgnikiem - SIGMA	11
Lighting poles with bracket - SIGMA	
Słupy z wysięgnikiem - EPSILON	12
Lighting poles with bracket - EPSILON	
Słupy z wysięgnikiem - ZETA	13
Lighting poles with bracket - ZETA	
Słupy oświetleniowe z cechami bezpieczeństwa biernego	14
The lighting poles with passive safety attributes	
Słup oświetleniowy – przegubowy	15
Hinged lighting poles	
Maszy 10÷25 m	16
Masts 10÷25 m	
Wieże oświetleniowe	17
Lighting Towers	
Konstrukcje specjalne	18
Special structures	
Korony / Wysięgniki	19
Crowns / Brackets	
Stalowa konstrukcja odgromowa	20
Steel lightning protection structure	
Belki	21
Beams	
Główce	22
Heads	
Fundamenty	23
Foundations	
Strefy wiatrowe	24
Wind zones	
Informacje handlowe	25
Commercial information	

Producent nie ponosi odpowiedzialności za niewłaściwy dobór poszczególnych elementów stanowiących całość konstrukcji. Mimo dolażenia wszelkich starań nie gwarantujemy, że publikowane dane techniczne nie zawierają uchybień lub błędów. W przypadku jakichkolwiek wątpliwości prosimy o kontakt.

The manufacturer is not responsible for the incorrect selection of components constituting the entire structure. Despite our best efforts, we do not guarantee that the published technical data does not contain any lapses or mistakes. In case of any doubts, please contact us.





elmonter



elmonter

Od 1993 roku produkujemy dla Państwa konstrukcje stalowe. Nasza oferta obejmuje trzy grupy asortymentowe:

- Oświetlenie
- Energetyka
- Konstrukcje specjalne

Przekazujemy Państwu kolejny katalog słupów i masztów oświetleniowych.

Zapraszamy do współpracy.

Dla uzyskania dodatkowych informacji zapraszamy na naszą stronę internetową www.elmonter.pl

Since 1993 we have been manufacturing steel structures for you. Our offer includes three groups of assortment:

- Lighting*
- Energetics*
- Special constructions*

We present you the next catalog of columns and lighting masts.

We invite you to cooperation.

For further information please visit our website www.elmonter.pl

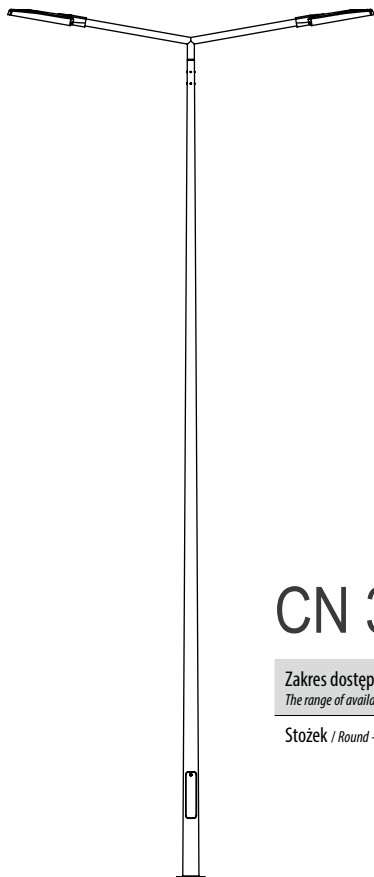

CN 3÷12 m

Zakres dostępnych wysokości <i>The range of available heights</i>	3 ÷ 12 m
--	----------

Stożek / Round - conical

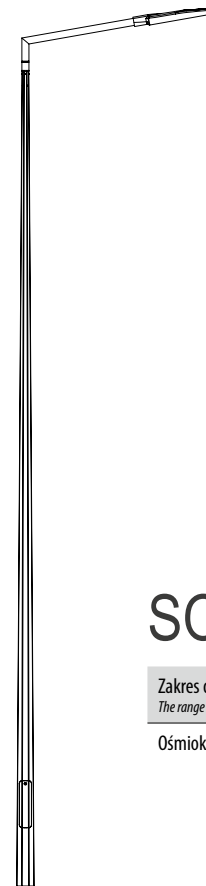

SO 3÷9 m

Zakres dostępnych wysokości <i>The range of available heights</i>	3 ÷ 9 m
--	---------

Ośmiokąt / Octagonal - conical

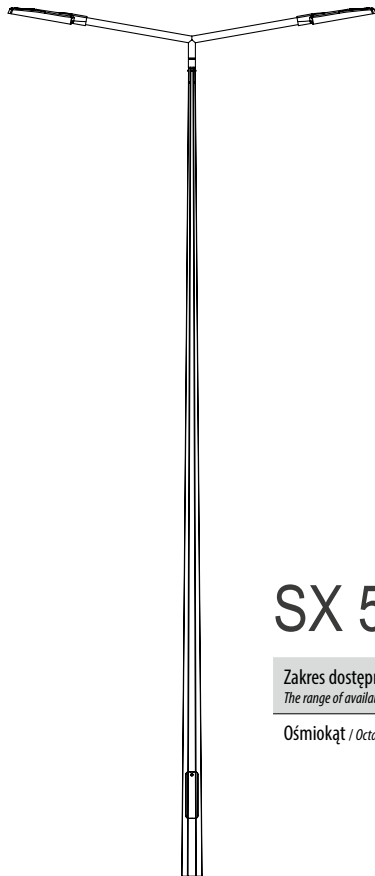

SX 5÷12 m

Zakres dostępnych wysokości <i>The range of available heights</i>	5 ÷ 12 m
--	----------

Ośmiokąt / Octagonal - conical



SRN 3÷8 m











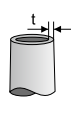
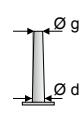
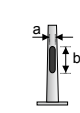

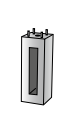
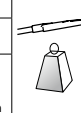
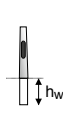



























Zakres dostępnych wysokości <i>The range of available heights</i>	3 ÷ 8 m
--	---------











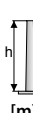
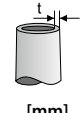
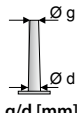
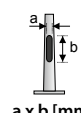
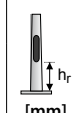
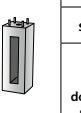
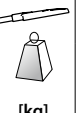
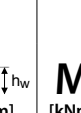























Rura / Tubular



Parametry techniczne pokazanej oprawy typu Tweet zawarte są w katalogu „Oprawy Oświetleniowe” firmy ELMONTER. Masy dotyczą słupa bez wysięgnika i oprawy.

Technical parameters of the shown Tweet luminaire are included in the ELMONTER's "Lighting Fixtures" catalog. The weights apply to the pole without the bracket and the luminaire.









Typ Type	Przekrój Profile	 [m]	 [mm]	 g/d [mm]	 a x b [mm]	 [mm]		maksymalna powierzchnia wiatrowa [m ²] max wind area					M [kNm]	T [kN]	
								strefa wiatrowa / wind zone							
								 do 300 m n.p.m.	 do 300 m n.p.m.	 do 450 m n.p.m.					
CN 3/2,5/60/F160		3	2,5	60/94	70x400	500	D16/100	0,78	0,53	0,64	30	-	1,93	0,79	19
CN 3/2,5/60/W		3	2,5	60/94	70x400	600	-	0,78	0,53	0,64	30	0,6	1,93	0,79	19
CN 3/3/60/F160		3	3	60/94	70x400	500	D16/100	0,99	0,68	0,82	40	-	2,41	0,95	22
CN 3/3/60/W		3	3	60/94	70x400	600	-	1,00	0,69	0,82	40	0,6	2,41	0,95	22
SO 3/3/F160		3	3	60/160	70x400	500	D16/120	3,05	2,13	2,53	50	-	6,50	2,40	28
SRN 3-2/60/F160		3	2,9-4	60/114	85x400	600	D16/100	1,24	0,86	1,02	15	-	3,17	1,23	27
SRN 3-2/60/W		3	2,9-4	60/108	85x400	600	-	1,24	0,86	1,02	15	0,6	3,18	1,23	28
CN 3,5/2,5/60/F160		3,5	2,5	60/99	70x400	500	D16/100	0,76	0,51	0,62	30	-	2,31	0,84	22
CN 3,5/2,5/60/W		3,5	2,5	60/99	70x400	600	-	0,76	0,51	0,62	30	0,6	2,31	0,84	23
SRN 3,5-2/60/F160		3,5	2,9-4	60/114	85x400	600	D16/100	0,91	0,62	0,75	15	-	2,98	1,05	29
SRN 3,5-2/60/W		3,5	2,9-4	60/108	85x400	600	-	0,91	0,62	0,75	15	0,6	2,96	1,04	31
CN 4/2,5/60/F160		4	2,5	60/105	70x400	500	D16/100	0,72	0,47	0,58	30	-	2,66	0,88	25
CN 4/2,5/60/W		4	2,5	60/105	70x400	600	-	0,72	0,47	0,58	30	0,8	2,66	0,88	28
CN 4/3/60/F160		4	3	60/105	70x400	500	D16/100	0,94	0,63	0,76	40	-	3,31	1,04	29
CN 4/3/60/W		4	3	60/105	70x400	600	-	0,94	0,63	0,77	40	0,8	3,31	1,04	32
SO 4/3/F160		4	3	60/160	70x400	500	D16/120	2,07	1,41	1,70	50	-	6,50	1,95	37
SRN 4-2/60/F160		4	2,9-4	60/114	85x400	600	D16/100	0,73	0,50	0,60	15	-	2,98	0,98	32
SRN 4-2/60/W		4	2,9-4	60/108	85x400	600	-	0,73	0,50	0,60	15	0,8	3,01	0,98	36
CN 4,5/2,5/60/F160		4,5	2,5	60/110	70x400	500	D16/100	0,68	0,44	0,54	30	-	3,07	0,93	28
CN 4,5/2,5/60/W		4,5	2,5	60/110	70x400	600	-	0,68	0,44	0,54	30	0,8	3,07	0,93	32
SRN 4,5-2/60/F160		4,5	2,9-4	60/114	85x400	600	D16/100	0,54	0,35	0,43	15	-	2,81	0,91	35
SRN 4,5-2/60/W		4,5	2,9-4	60/108	85x400	600	-	0,54	0,35	0,43	15	0,8	2,88	0,91	38
CN 5/2,5/60/F160		5	2,5	60/116	85x400	500	D16/100	0,48	0,29	0,37	30	-	2,88	0,85	32
CN 5/2,5/60/W		5	2,5	60/116	85x400	600	-	0,48	0,29	0,37	30	0,8	2,88	0,85	36
CN 5/3/60/F160		5	3	60/116	85x400	500	D16/120	0,69	0,43	0,54	40	-	3,71	1,02	37
CN 5/3/60/W		5	3	60/116	85x400	600	-	0,68	0,43	0,54	40	0,8	3,71	1,02	42
CN 5/4/64/F160		5	4	61/117	85x400	500	D16/120	1,09	0,73	0,89	40	-	5,26	1,33	49
CN 5/4/64/W		5	4	61/117	85x400	600	-	1,08	0,72	0,88	40	0,8	5,26	1,33	56
CN 5/3/76/F160		5	3	76/132	85x400	500	D16/120	1,09	0,73	0,88	40	-	5,33	1,35	45
CN 5/3/76/W		5	3	76/132	85x400	600	-	1,10	0,73	0,89	40	0,8	5,33	1,35	49
CN 5/4/76/F160		5	4	76/132	85x400	500	D16/140	1,73	1,18	1,42	40	-	7,63	1,80	57
CN 5/4/76/W		5	4	76/132	85x400	600	-	1,73	1,18	1,42	40	0,8	7,63	1,80	64
SO 5/3/F160		5	3	60/160	70x400	500	D16/120	1,36	0,89	1,09	50	-	6,50	1,73	45
SO 5/4/F160		5	4	63/161	70x400	500	D16/160	2,83	1,96	2,34	50	-	12,10	2,84	59
SX 5/3/F220		5	3	60/189	100x400	500	D22/150	2,21	1,51	1,82	50	-	9,71	2,42	57
SX 5/4/F220		5	4	63/190	100x400	500	D22/150	3,46	2,41	2,87	50	-	14,14	3,23	73
SRN 5-2/60/F160		5	2,9-4	60/114	85x400	600	D16/100	0,51	0,32	0,40	15	-	3,32	0,97	40
SRN 5-2/60/W		5	2,9-4	60/108	85x400	600	-	0,51	0,32	0,40	15	0,8	3,32	0,97	43

Typ Type	Przekrój Profile	 [m]	 [mm]	 g/d [mm]	 a x b [mm]	 [mm]		maksymalna powierzchnia wiatrowa [m ²] max wind area			 [kg]	 [m]	M [kNm]	T [kN]	 [kg]
								strefa wiatrowa / wind zone							
								 do 300 m n.p.m.	 do 300 m n.p.m.	 do 450 m n.p.m.					
CN 6/2,5/60/F160		6	2,5	60/127	85x400	500	D16/120	0,43	0,25	0,33	30	-	3,95	1,25	40
CN 6/2,5/60/W		6	2,5	60/127	85x400	600	-	0,43	0,25	0,33	30	1	3,95	1,25	46
CN 6/3/60/F160		6	3	60/127	85x400	500	D16/120	0,63	0,39	0,50	40	-	4,83	1,16	47
CN 6/3/60/W		6	3	60/127	85x400	600	-	0,63	0,39	0,49	40	1	4,83	1,16	54
CN 6/4/64/F160		6	4	61/128	85x400	500	D16/140	1,05	0,69	0,85	40	-	6,85	1,49	62
CN 6/4/64/W		6	4	61/128	85x400	600	-	1,05	0,69	0,85	40	1	6,85	1,49	72
CN 6/3/76/F160		6	3	76/143	85x400	500	D16/140	0,99	0,64	0,79	40	-	6,66	1,45	56
CN 6/3/76/W		6	3	76/143	85x400	600	-	0,99	0,65	0,80	40	1	6,66	1,45	63
CN 6/4/76/F160		6	4	76/143	85x400	500	D16/140	1,58	1,06	1,29	40	-	9,39	1,85	71
CN 6/4/76/W		6	4	76/143	85x400	600	-	1,58	1,07	1,29	40	1	9,39	1,85	83
SO 6/3/F160		6	3	60/160	100x400	500	D16/120	0,89	0,54	0,70	50	-	6,50	1,62	53
SO 6/4/F160		6	4	63/161	100x400	500	D16/160	2,28	1,55	1,86	50	-	13,44	2,77	71
SX 6/3/F220		6	3	60/189	100x400	500	D22/150	2,31	1,57	1,89	50	-	13,56	2,85	67
SX 6/4/F220		6	4	63/190	100x400	500	D22/180	3,80	2,63	3,14	50	-	20,49	4,00	86
SRN 6-3/60/F160		6	2,9-4	60/114	85x400	600	D16/120	0,54	0,31	0,41	15	-	4,63	1,13	49
SRN 6-3/60/W		6	2,9-4	60/114	85x400	600	-	0,54	0,31	0,41	15	1	4,59	1,14	56
CN 7/3/60/F160		7	3	60/138	85x400	500	D16/120	0,59	0,35	0,45	40	-	6,02	1,29	58
CN 7/3/60/W		7	3	60/138	85x400	600	-	0,59	0,35	0,45	40	1,2	6,02	1,29	68
CN 7/4/64/F160		7	4	61/139	85x400	500	D16/140	1,02	0,65	0,81	40	-	8,66	1,65	77
CN 7/4/64/W		7	4	61/139	85x400	600	-	1,01	0,65	0,81	40	1,2	8,66	1,65	90
CN 7/3/76/F160		7	3	76/154	85x400	500	D16/140	0,88	0,56	0,70	40	-	7,96	1,54	67
CN 7/3/76/W		7	3	76/154	85x400	600	-	0,89	0,57	0,70	40	1,2	7,96	1,54	78
CN 7/4/76/F160		7	4	76/154	85x400	500	D16/160	1,46	0,98	1,19	40	-	11,34	2,02	87
CN 7/4/76/W		7	4	76/154	85x400	600	-	1,46	0,98	1,19	40	1,2	11,34	2,02	103
SO 7/3/F160		7	3	60/160	100x400	500	D16/140	0,97	0,6	0,76	50	-	9,25	1,98	62
SO 7/4/F160		7	4	63/161	100x400	500	D16/160	1,70	1,12	1,37	50	-	13,7	2,61	82
SX 7/3/F220		7	3	60/189	100x400	500	D22/150	1,73	1,13	1,39	50	-	13,8	2,69	76
SX 7/4/F220		7	4	63/190	100x400	500	D22/180	2,93	1,99	2,40	50	-	20,88	3,69	99
SRN 7-3/60/F160		7	2,9-4	60/114	85x400	600	D16/120	0,34	0,16	0,23	15	-	4,64	1,12	57
SRN 7-3/60/W		7	2,9-4	60/114	85x400	600	-	0,34	0,16	0,23	15	1,2	4,64	1,12	66

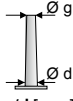
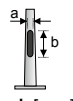
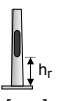
- Słupy wielokątne od 6m wysokości wykonywane są ze stali S355.
- Podane powierzchnie mają jedynie charakter informacyjny.
- Nie zaleca się montażu większej liczby opraw ulicznych niż 4 szt/słup o masie pojedynczej oprawy 10kg i powierzchni bocznej 0,1m² przy równoczesnym spełnianiu warunków zawartych w tabeli.
- Dobrane fundamenty dostosowane są do maksymalnego danego obciążenia słupa/masztu, przy zamontowaniu opraw/naświetlaczy o parametrach zawartych w tabeli.
- Dla słupów stożkowych klasa obciążenia konstrukcji "B", dla słupów rurowych typu SRN klasa obciążenia konstrukcji "A".
- Średnica ośmiokąta to średnica okręgu opisanego.
- Powierzchnie wiatrowe wyznaczono dla Cx=1,0 i terenu kat. 2.

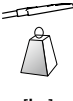
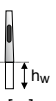





















- Polygonal poles from 6 m high are made of steel type S355.
- Areas are provided for information purposes only.
- It is not recommended to install more than 4 pcs. of street luminaires / pole with a weight of a single luminaire 10 kg and a side area of 0.1 m², while meeting the conditions contained in the table.
- The selected foundations are adjusted to the maximum load of the column / mast, with the installation of luminaires / floodlights with the parameters included in the table.
- For conical columns - the construction load class "B", for tubular columns type SRN - the load class "A".
- The diameter of the octagon is the diameter of the circumscribed circle.
- Wind surfaces were determined for Cx = 1.0 and terrain cat. 2.





Typ Type	Przekrój Profile	 [m]	 [mm]	 g/d [mm]	 a x b [mm]	 [mm]		maksymalna powierzchnia wiatrowa [m ²] max wind area			 [kg]	 [m]	M [kNm]	T [kN]	 [kg]
								strefa wiatrowa / wind zone							
								 do 300 m n.p.m.	 do 300 m n.p.m.	 do 450 m n.p.m.					
CN 8/3/60/F160	⊙	8	3	60/149	85x400	500	D16/140	0,54	0,30	0,40	40	-	7,32	1,41	70
CN 8/3/60/W	⊙	8	3	60/149	85x400	600	-	0,54	0,30	0,40	40	1,2	7,32	1,41	80
CN 8/4/64/F160	⊙	8	4	61/150	85x400	500	D16/160	0,98	0,62	0,77	40	-	10,51	1,80	91
CN 8/4/64/W	⊙	8	4	61/150	85x400	600	-	0,98	0,62	0,77	40	1,2	10,51	1,80	107
CN 8/3/76/F220	⊙	8	3	76/165	100x400	500	D22/150	0,68	0,42	0,53	40	-	8,46	1,52	84
CN 8/3/76/W	⊙	8	3	76/165	100x400	600	-	0,69	0,42	0,53	40	1,2	8,46	1,52	91
CN 8/4/76/F220	⊙	8	4	76/165	100x400	500	D22/150	1,21	0,79	0,97	40	-	12,14	1,97	108
CN 8/4/76/W	⊙	8	4	76/165	100x400	600	-	1,20	0,79	0,97	40	1,2	12,14	1,97	121
CN 8/4/89/F220	⊙	8	4	89/178	100x400	500	D22/150	1,56	1,06	1,27	50	-	14,8	2,28	119
SO 8/3/F160	○	8	3	60/160	100x400	500	D16/140	0,67	0,36	0,50	50	-	9,33	1,45	71
SO 8/4/F160	○	8	4	63/161	100x400	500	D16/160	1,27	0,80	1,01	50	-	13,96	2,52	93
SX 8/3/F220	○	8	3	60/189	100x400	500	D22/150	1,29	0,81	1,02	50	-	14,13	2,62	86
SX 8/4/F220	○	8	4	63/190	100x400	500	D22/180	2,28	1,52	1,85	50	-	21,31	3,50	111
SRN 8-3/60/F160	○	8	2,9-4	60/133	85x400	600	D16/140	0,44	0,27	0,35	15	-	7,43	1,48	75
SRN 8-3/60/W	○	8	2,9-4	60/133	85x400	600	-	0,44	0,27	0,35	15	1,2	7,48	1,48	90
CN 9/3/60/F160	⊙	9	3	60/160	85x400	500	D16/140	0,49	0,27	0,37	40	-	8,66	1,53	82
CN 9/3/60/W	⊙	9	3	60/160	85x400	600	-	0,49	0,27	0,36	40	1,5	8,66	1,53	97
CN 9/4/64/F160	⊙	9	4	61/161	85x400	500	D16/160	0,94	0,59	0,74	40	-	12,55	1,94	108
CN 9/4/64/W	⊙	9	4	61/161	85x400	600	-	0,94	0,59	0,74	40	1,5	12,55	1,94	130
CN 9/3/76/F220	⊙	9	3	76/177	100x400	500	D22/150	0,63	0,37	0,48	40	-	9,84	1,61	97
CN 9/3/76/W	⊙	9	3	76/177	100x400	600	-	0,63	0,37	0,48	40	1,5	9,84	1,61	110
CN 9/4/76/F220	⊙	9	4	76/177	100x400	500	D22/150	1,18	0,77	0,94	40	-	14,53	2,12	125
CN 9/4/76/W	⊙	9	4	76/177	100x400	600	-	1,17	0,77	0,94	40	1,5	14,53	2,12	146
CN 9/4/89/F220	⊙	9	4	89/189	100x400	500	D22/180	1,47	0,99	1,20	50	-	17,13	2,37	137
SO 9/3/F160	○	9	3	60/160	100x400	500	D16/140	0,43	0,18	0,29	50	-	9,47	1,98	79
SO 9/4/F160	○	9	4	63/161	100x400	500	D16/160	0,94	0,54	0,72	50	-	14,11	2,35	104
SX 9/3/F220	○	9	3	60/189	100x400	500	D22/150	0,90	0,50	0,67	50	-	13,70	2,52	95
SX 9/4/F220	○	9	4	63/190	100x400	500	D22/180	1,78	1,14	1,42	50	-	21,52	3,38	124
CN 10/3/60/F220	⊙	10	3	60/171	85x400	500	D22/150	0,45	0,23	0,32	40	-	10,10	1,63	99
CN 10/3/60/W	⊙	10	3	60/171	85x400	600	-	0,45	0,23	0,32	40	1,5	10,10	1,63	111
CN 10/4/64/F220	⊙	10	4	61/172	85x400	500	D22/150	0,91	0,56	0,71	40	-	14,68	2,07	129
CN 10/4/64/W	⊙	10	4	61/172	85x400	600	-	0,91	0,56	0,71	40	1,5	14,68	2,07	149
CN 10/3/76/F220	⊙	10	3	76/188	100x400	500	D22/150	0,57	0,33	0,43	40	-	11,35	1,71	111
CN 10/3/76/W	⊙	10	3	76/188	100x400	600	-	0,57	0,33	0,43	40	1,5	11,35	1,71	126
CN 10/4/76/F220	⊙	10	4	76/188	100x400	500	D22/180	1,13	0,73	0,90	40	-	16,81	2,22	144
CN 10/4/76/W	⊙	10	4	76/188	100x400	600	-	1,13	0,73	0,90	40	1,5	16,81	2,22	166
CN 10/4/89/F220	⊙	10	4	89/200	100x400	500	D22/180	1,40	0,94	1,14	50	-	19,6	2,50	157
SX 10/3/F220	○	10	3	60/189	100x400	500	D22/150	0,62	0,29	0,43	50	-	13,83	2,54	104
SX 10/4/F220	○	10	4	63/190	100x400	500	D22/180	1,39	0,84	1,09	50	-	21,78	3,31	136

○ - ośmiokąt / octagonal-conical ○ - rura / tubular ⊙ - stożek / round-conical

11÷12m Słupy oświetleniowe / Lighting poles

Typ Type	Przekrój Profile	 [m]	 [mm]	 g/d [mm]	 a x b [mm]	 [mm]		maksymalna powierzchnia wiatrowa [m ²] max wind area			 [kg]	 [m]	M [kNm]	T [kN]	 [kg]
								strefa wiatrowa / wind zone							
								I do 300 m n.p.m.	II do 300 m n.p.m.	III do 450 m n.p.m.					
CN 11/3/60/F220		11	3	60/182	85x400	500	D22/150	0,41	0,20	0,28	40	-	11,58	1,73	112
CN 11/4/64/F220		11	4	61/183	85x400	500	D22/180	0,88	0,54	0,68	40	-	17,05	2,21	147
CN 11/3/76/F220		11	3	76/199	100x400	500	D22/150	0,52	0,3	0,39	40	-	13,02	1,82	126
CN 11/4/76/F220		11	4	76/199	100x400	500	D22/180	1,09	0,70	0,86	40	-	19,23	2,37	164
CN 11/4/89/F220		11	4	89/212	100x400	500	D22/180	1,33	0,90	1,08	50	-	22,03	2,57	179
SX 11/3/F220		11	3	60/189	100x400	500	D22/150	0,39	0,11	0,23	50	-	13,88	2,58	114
SX 11/4/F220		11	4	63/190	100x400	500	D22/180	0,99	0,60	0,77	50	-	22,17	3,31	149
CN 12/3/60/F220		12	3	60/194	85x400	500	D22/150	0,38	0,18	0,26	40	-	13,32	1,85	127
CN 12/4/64/F220		12	4	61/195	85x400	500	D22/180	0,87	0,53	0,67	40	-	19,66	2,36	167
CN 12/3/76/F220		12	3	76/210	100x400	500	D22/150	0,48	0,26	0,35	40	-	14,63	1,84	141
CN 12/4/76/F220		12	4	76/210	100x400	500	D22/180	1,05	0,68	0,83	40	-	21,91	2,52	185
CN 12/4/89/F250		12	4	89/223	100x400	500	B-150	1,30	0,88	1,06	50	-	25,16	2,80	199
SX 12/3/F220		12	3	60/189	100x400	500	D22/150	0,19	0	0,06	50	-	13,83	2,43	123
SX 12/4/F220		12	4	63/190	100x400	500	D22/180	0,67	0,36	0,50	50	-	21,82	3,28	162

 - ośmiokąt / octagonal-conical  - rura / tubular  - stożek / round-conical

- Słupy wielokątne od 6m wysokości wykonywane są ze stali S355.
- Podane powierzchnie mają jedynie charakter informacyjny.
- Nie zaleca się montażu większej liczby opraw ulicznych niż 4 szt/słup o masie pojedynczej oprawy 10kg i powierzchni bocznej 0,1m² przy równoczesnym spełnianiu warunków zawartych w tabeli.
- Dobrane fundamenty dostosowane są do maksymalnego danego obciążenia słupa/masztu, przy zamontowaniu opraw/naświetlaczy o parametrach zawartych w tabeli.
- Dla słupów stożkowych klasa obciążenia konstrukcji "B", dla słupów rurowych typu SRN klasa obciążenia konstrukcji "A".
- Średnica ośmiokąta to średnica okręgu opisanego.
- Powierzchnie wiatrowe wyznaczone dla Cx=1,0 i terenu kat. 2.
- Polygonal poles from 6 m high are made of steel type S355.
- Areas are provided for information purposes only.
- It is not recommended to install more than 4 pcs. of street luminaires / pole with a weight of a single luminaire 10 kg and a side area of 0.1 m², while meeting the conditions contained in the table.
- The selected foundations are adjusted to the maximum load of the column / mast, with the installation of luminaires / floodlights with the parameters included in the table.
- For conical columns - the construction load class "B", for tubular columns type SRN - the load class "A".
- The diameter of the octagon is the diameter of the circumscribed circle.
- Wind surfaces were determined for Cx = 1.0 and terrain cat. 2.



BETA 5÷9 m

Zakres dostępnych wysokości / Range of available heights	5 ÷ 9 m
Ilość ramion wysięgnika / Number of bracket's arms	1÷2
Wysięg wysięgnika / Outreach of bracket	1÷1,5
Średnica mocowania oprawy / Luminaire mounting diameter	Ø 60 mm
Kąt między ramionami wysięgnika / The angle between the bracket's arms	180°
Kąt podniesienia wysięgnika / Bracket's lifting angle	10°
Ośmiokąt / Octagonal – conical	○

SIGMA 7÷10 m

Zakres dostępnych wysokości / Range of available heights	7 ÷ 10 m
Ilość ramion wysięgnika / Number of bracket's arms	1÷2
Wysięg wysięgnika / Outreach of bracket	1÷1,5
Średnica mocowania oprawy / Luminaire mounting diameter	Ø 60 mm
Kąt między ramionami wysięgnika / The angle between the bracket's arms	180°
Kąt podniesienia wysięgnika / Bracket's lifting angle	10°
Ośmiokąt / Octagonal – conical	○

EPSILON 9÷12 m

Zakres dostępnych wysokości / Range of available heights	9 ÷ 12 m
Ilość ramion wysięgnika / Number of bracket's arms	1÷2
Wysięg wysięgnika / Outreach of bracket	1÷2
Średnica mocowania oprawy / Luminaire mounting diameter	Ø 60 mm
Kąt między ramionami wysięgnika / The angle between the bracket's arms	180°
Kąt podniesienia wysięgnika / Bracket's lifting angle	10°
Ośmiokąt / Octagonal – conical	○

ZETA 5÷10 m





Zakres dostępnych wysokości / Range of available heights	5 ÷ 10 m
Ilość ramion wysięgnika / Number of bracket's arms	1÷2
Wysięg wysięgnika / Outreach of bracket	1÷1,5
Średnica mocowania oprawy / Luminaire mounting diameter	Ø 60 mm
Kąt między ramionami wysięgnika / The angle between the bracket's arms	180°
Kąt podniesienia wysięgnika / Bracket's lifting angle	10°
Stożek / Round-conical	◎

Parametry techniczne pokazanej oprawy typu Tweet zawarte są w katalogu „Oprawy Oświetleniowe” firmy ELMONTER.

Dobre fundamenty dostosowane są do maksymalnego danego obciążenia słupa/masztu, przy zamontowaniu opraw/naświetlaczy o parametrach zawartych w tabeli wysokości zawieszenia oprawy.

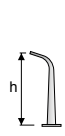
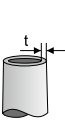
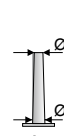
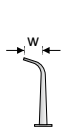
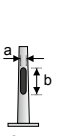
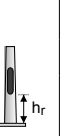
Technical parameters of the shown Tweet luminaire are included in the ELMONTER's "Lighting Fixtures" catalog.

The selected foundations are adjusted to the maximum load of the pole / mast, when installing luminaires / floodlights with the parameters included in the table of the luminaire suspension height.











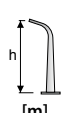

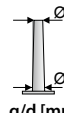

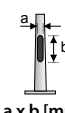
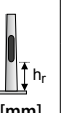











Typ Type	Przekrój Profile				Ilość ramion Number of arms					maksymalna powierzchnia wiatrowa [m ²] max wind area						
										strefa wiatrowa / wind zone					[kg]	[kg]
										do 300 m n.p.m.	do 300 m n.p.m.	do 450 m n.p.m.				
BETA 5/1/1 SO 4/3/F160+W16/1/1/1-60/10	○	5	3	60/160	1	1000	70x400	500	D16/120	0,85	0,57	0,69	15	45		
BETA 5/1/1,5 SO 4/3/F160+W16/1/1/1,5-60/10	○	5	3	60/160	1	1500	70x400	500	D16/120	0,64	0,41	0,51	15	47		
BETA 5/2/1 SO 4/3/F160+W16/1/2/1-60/10/180	○	5	3	60/160	2	1000	70x400	500	D16/120	1,28	0,80	1,00	30	50		
BETA 5/2/1,5 SO 4/3/F160+W16/1/2/1,5-60/10/180	○	5	3	60/160	2	1500	70x400	500	D16/120	1,21	0,73	0,94	30	55		
BETA 6/1/1 SO 5/3/F160+W16/1/1/1-60/10	○	6	3	60/160	1	1000	70x400	500	D16/120	0,71	0,46	0,57	15	53		
BETA 6/1/1,5 SO 5/3/F160+W16/1/1/1,5-60/10	○	6	3	60/160	1	1500	70x400	500	D16/120	0,54	0,34	0,43	15	55		
BETA 6/2/1 SO 5/3/F160+W16/1/2/1-60/10/180	○	6	3	60/160	2	1000	70x400	500	D16/120	0,83	0,46	0,62	30	58		
BETA 6/2/1,5 SO 5/3/F160+W16/1/2/1,5-60/10/180	○	6	3	60/160	2	1500	70x400	500	D16/120	0,76	0,40	0,56	30	63		
BETA 7/1/1 SO 6/3/F160+W16/1/1/1-60/10	○	7	3	60/160	1	1000	100x400	500	D16/120	0,57	0,35	0,44	15	61		
BETA 7/1/1,5 SO 6/3/F160+W16/1/1/1,5-60/10	○	7	3	60/160	1	1500	100x400	500	D16/120	0,41	0,25	0,33	15	63		
BETA 7/2/1 SO 6/3/F160+W16/1/2/1-60/10/180	○	7	3	60/160	2	1000	100x400	500	D16/120	0,51	0,22	0,34	30	66		
BETA 7/2/1,5 SO 6/3/F160+W16/1/2/1,5-60/10/180	○	7	3	60/160	2	1500	100x400	500	D16/120	0,44	0,14	0,28	30	71		
BETA 8/1/1 SO 7/3/F160+W16/1/1/1-60/10	○	8	3	60/160	1	1000	100x400	500	D16/140	0,44	0,24	0,33	15	70		
BETA 8/1/1,5 SO 7/3/F160+W16/1/1/1,5-60/10	○	8	3	60/160	1	1500	100x400	500	D16/140	0,33	0,17	0,24	15	72		
BETA 8/2/1 SO 7/3/F160+W16/1/2/1-60/10/180	○	8	3	60/160	2	1000	100x400	500	D16/140	0,58	0,27	0,41	30	75		
BETA 8/2/1,5 SO 7/3/F160+W16/1/2/1,5-60/10/180	○	8	3	60/160	2	1500	100x400	500	D16/140	0,52	0,21	0,34	30	80		
BETA 9/1/1 SO 8/3/F160+W16/1/1/1-60/10	○	9	3	60/160	1	1000	100x400	500	D16/140	0,32	0,14	0,22	15	80		
BETA 9/1/1,5 SO 8/3/F160+W16/1/1/1,5-60/10	○	9	3	60/160	1	1500	100x400	500	D16/140	0,23	0,08	0,15	15	82		
BETA 9/2/1 SO 8/3/F160+W16/1/2/1-60/10/180	○	9	3	60/160	2	1000	100x400	500	D16/140	0,36	0,10	0,21	30	85		
BETA 9/2/1,5 SO 8/3/F160+W16/1/2/1,5-60/10/180	○	9	3	60/160	2	1500	100x400	500	D16/140	0,29	0,03	0,15	30	90		

○ - ośmiokąt / octagonal-conical

Jest to przykładowe zestawienie słupa z wysięgnikiem.
This is an example combination of a pole and a bracket.











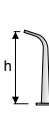

























- Słupy wielokątne od 6m wysokości wykonywane są ze stali S355.
- Podane powierzchnie mają jedynie charakter informacyjny.
- Nie zaleca się montażu większej liczby opraw ulicznych niż 4 szt/słup o masie pojedynczej oprawy 10kg i powierzchni bocznej 0,1m² przy równoczesnym spełnieniu warunków zawartych w tabeli.
- Dobre fundamenty dostosowane są do maksymalnego danego obciążenia słupa/masztu, przy zamontowaniu opraw/naświetlaczy o parametrach zawartych w tabeli.
- Dla słupów stożkowych klasa obciążenia konstrukcji "B", dla słupów rurowych typu SRN klasa obciążenia konstrukcji "A".
- Średnica ośmiokąta to średnica okręgu opisanego.
- Powierzchnie wiatrowe wyznaczone dla Cx=1,0 i terenu kat. 2.
- Polygonal poles from 6 m high are made of steel type S355.
- Areas are provided for information purposes only.
- It is not recommended to install more than 4 pcs. of street luminaires / pole with a weight of a single luminaire 10 kg and a side area of 0.1 m², while meeting the conditions contained in the table.
- The selected foundations are adjusted to the maximum load of the column / mast, with the installation of luminaires / floodlights with the parameters included in the table.
- For conical columns - the construction load class "B", for tubular columns type SRN - the load class "A".
- The diameter of the octagon is the diameter of the circumscribed circle.
- Wind surfaces were determined for Cx = 1.0 and terrain cat. 2.



Typ Type	Przekrój Profile				Ilość ramion Number of arms					maksymalna powierzchnia wiatrowa [m ²] max wind area				
										strefa wiatrowa / wind zone				
										 do 300 m n.p.m.	 do 300 m n.p.m.	 do 450 m n.p.m.		
SIGMA 7/1/1 SX 5/3/F220+W16/2/1/1-60/10		7	3	60/189	1	1000	100x400	500	D22/150	0,31	0,17	0,22	15	70
SIGMA 7/1/1,5 SX 5/3/F220+W16/2/1/1,5-60/10		7	3	60/189	1	1500	100x400	500	D22/150	0,21	0,09	0,12	15	72
SIGMA 7/2/1 SX 5/3/F220+W16/2/2/1-60/10/180		7	3	60/189	2	1000	100x400	500	D22/150	0,52	0,31	0,41	30	75
SIGMA 7/2/1,5 SX 5/3/F220+W16/2/2/1,5-60/10/180		7	3	60/189	2	1500	100x400	500	D22/150	0,49	0,21	0,31	30	79
SIGMA 8/1/1 SX 6/3/F220+W16/2/1/1-60/10		8	3	60/189	1	1000	100x400	500	D22/150	0,51	0,32	0,40	15	80
SIGMA 8/1/1,5 SX 6/3/F220+W16/2/1/1,5-60/10		8	3	60/189	1	1500	100x400	500	D22/150	0,41	0,21	0,30	15	82
SIGMA 8/2/1 SX 6/3/F220+W16/2/2/1-60/10/180		8	3	60/189	2	1000	100x400	500	D22/150	0,83	0,50	0,69	30	85
SIGMA 8/2/1,5 SX 6/3/F220+W16/2/2/1,5-60/10/180		8	3	60/189	2	1500	100x400	500	D22/150	0,80	0,42	0,60	30	89
SIGMA 9/1/1 SX 7/3/F220+W16/2/1/1-60/10		9	3	60/189	1	1000	100x400	500	D22/150	0,50	0,31	0,40	15	90
SIGMA 9/1/1,5 SX 7/3/F220+W16/2/1/1,5-60/10		9	3	60/189	1	1500	100x400	500	D22/150	0,34	0,21	0,27	15	91
SIGMA 9/2/1 SX 7/3/F220+W16/2/2/1-60/10/180		9	3	60/189	2	1000	100x400	500	D22/150	0,68	0,35	0,50	30	100
SIGMA 9/2/1,5 SX 7/3/F220+W16/2/2/1,5-60/10/180		9	3	60/189	2	1500	100x400	500	D22/150	0,62	0,27	0,40	30	99
SIGMA 10/1/1 SX 8/3/F220+W16/2/1/1-60/10		10	3	60/189	1	1000	100x400	500	D22/150	0,40	0,19	0,30	15	100
SIGMA 10/1/1,5 SX 8/3/F220+W16/2/1/1,5-60/10		10	3	60/189	1	1500	100x400	500	D22/150	0,31	0,15	0,21	15	102
SIGMA 10/2/1 SX 8/3/F220+W16/2/2/1-60/10/180		10	3	60/189	2	1000	100x400	500	D22/150	0,39	0,17	0,29	30	105
SIGMA 10/2/1,5 SX 8/3/F220+W16/2/2/1,5-60/10/180		10	3	60/189	2	1500	100x400	500	D22/150	0,33	0,13	0,21	30	110

○ - ośmiokąt / octagonal-conical

- Słupy wielokątne od 6m wysokości wykonywane są ze stali S355.
- Podane powierzchnie mają jedynie charakter informacyjny.
- Nie zaleca się montażu większej liczby opraw ulicznych niż 4 szt/słup o masie pojedynczej oprawy 10kg i powierzchni bocznej 0,1m² przy równoczesnym spełnianiu warunków zawartych w tabeli.
- Dobrane fundamenty dostosowane są do maksymalnego danego obciążenia słupa/masztu, przy zamontowaniu opraw/naświetlaczy o parametrach zawartych w tabeli.
- Dla słupów stożkowych klasa obciążenia konstrukcji "B", dla słupów rurowych typu SRN klasa obciążenia konstrukcji "A".
- Średnica ośmiokąta to średnica okręgu opisanego.
- Powierzchnie wiatrowe wyznaczone dla Cx=1,0 i terenu kat. 2.
- Polygonal poles from 6 m high are made of steel type S355.
- Areas are provided for information purposes only.
- It is not recommended to install more than 4 pcs. of street luminaires / pole with a weight of a single luminaire 10 kg and a side area of 0.1 m², while meeting the conditions contained in the table.
- The selected foundations are adjusted to the maximum load of the column / mast, with the installation of luminaires / floodlights with the parameters included in the table.
- For conical columns -the construction load class "B", for tubular columns type SRN - the load class "A".
- The diameter of the octagon is the diameter of the circumscribed circle.
- Wind surfaces were determined for Cx = 1.0 and terrain cat. 2.



Typ Type	Przekrój Profile				Ilość ramion Number of arms					maksymalna powierzchnia wiatrowa [m ²] max wind area					
										strefa wiatrowa / wind zone					
															
									do 300 m n.p.m.	do 300 m n.p.m.	do 450 m n.p.m.				
EPSILON 9/1/1 SX 7/4/F220+W16/2/1/1-60/10		9	4	63/190	1	1000	100x400	500	D22/180	0,40	0,31	0,36	15	112	
EPSILON 9/1/1,5 SX 7/4/F220+W16/2/1/1,5-60/10		9	4	63/190	1	1500	100x400	500	D22/180	0,32	0,15	0,22	15	114	
EPSILON 9/1/2 SX 7/4/F220+W16/2/1/2-60/10		9	4	63/190	1	2000	100x400	500	D22/180	0,20	0,10	0,17	15	116	
EPSILON 9/2/1 SX 7/4/F220+W16/2/2/1-60/10/180		9	4	63/190	2	1000	100x400	500	D22/180	0,79	0,50	0,65	30	118	
EPSILON 9/2/1,5 SX 7/4/F220+W16/2/2/1,5-60/10/180		9	4	63/190	2	1500	100x400	500	D22/180	0,69	0,39	0,50	30	121	
EPSILON 9/2/2 SX 7/4/F220+W16/2/2/2-60/10/180		9	4	63/190	2	2000	100x400	500	D22/180	0,63	0,31	0,56	30	126	
EPSILON 10/1/1 SX 8/4/F220+W16/2/1/1-60/10		10	4	63/190	1	1000	100x400	500	D22/180	0,43	0,25	0,32	15	124	
EPSILON 10/1/1,5 SX 8/4/F220+W16/2/1/1,5-60/10		10	4	63/190	1	1500	100x400	500	D22/180	0,28	0,15	0,20	15	126	
EPSILON 10/1/2 SX 8/4/F220+W16/2/1/2-60/10		10	4	63/190	1	2000	100x400	500	D22/180	0,18	0,08	0,12	15	128	
EPSILON 10/2/1 SX 8/4/F220+W16/2/2/1-60/10/180		10	4	63/190	2	1000	100x400	500	D22/180	0,69	0,40	0,53	30	130	
EPSILON 10/2/1,5 SX 8/4/F220+W16/2/2/1,5-60/10/180		10	4	63/190	2	1500	100x400	500	D22/180	0,58	0,35	0,47	30	133	
EPSILON 10/2/2 SX 8/4/F220+W16/2/2/2-60/10/180		10	4	63/190	2	2000	100x400	500	D22/180	0,50	0,28	0,37	30	138	
EPSILON 11/1/1 SX 9/4/F220+W16/2/1/1-60/10		11	4	63/190	1	1000	100x400	500	D22/180	0,37	0,22	0,29	15	137	
EPSILON 11/1/1,5 SX 9/4/F220+W16/2/1/1,5-60/10		11	4	63/190	1	1500	100x400	500	D22/180	0,25	0,14	0,19	15	139	
EPSILON 11/1/2 SX 9/4/F220+W16/2/1/2-60/10		11	4	63/190	1	2000	100x400	500	D22/180	0,16	0,07	0,10	15	141	
EPSILON 11/2/1 SX 9/4/F220+W16/2/2/1-60/10/180		11	4	63/190	2	1000	100x400	500	D22/180	0,55	0,26	0,38	30	143	
EPSILON 11/2/1,5 SX 9/4/F220+W16/2/2/1,5-60/10/180		11	4	63/190	2	1500	100x400	500	D22/180	0,48	0,20	0,32	30	146	
EPSILON 11/2/2 SX 9/4/F220+W16/2/2/2-60/10/180		11	4	63/190	2	2000	100x400	500	D22/180	0,41	0,11	0,25	30	151	
EPSILON 12/1/1 SX 10/4/F220+W16/2/1/1-60/10		12	4	63/190	1	1000	100x400	500	D22/180	0,35	0,21	0,27	15	149	
EPSILON 12/1/1,5 SX 10/4/F220+W16/2/1/1,5-60/10		12	4	63/190	1	1500	100x400	500	D22/180	0,23	0,13	0,18	15	151	
EPSILON 12/1/2 SX 10/4/F220+W16/2/1/2-60/10		12	4	63/190	1	2000	100x400	500	D22/180	0,15	0,06	0,09	15	153	
EPSILON 12/2/1 SX 10/4/F220+W16/2/2/1-60/10/180		12	4	63/190	2	1000	100x400	500	D22/180	0,33	0,09	0,22	30	155	
EPSILON 12/2/1,5 SX 10/4/F220+W16/2/2/1,5-60/10/180		12	4	63/190	2	1500	100x400	500	D22/180	0,28	0,05	0,15	30	158	
EPSILON 12/2/2 SX 10/4/F220+W16/2/2/2-60/10/180		12	4	63/190	2	2000	100x400	500	D22/180	0,21	-	0,06	30	163	

○ - ośmiokąt / octagonal-conical

- Słupy wielokątne od 6m wysokości wykonywane są ze stali S355.
- Podane powierzchnie mają jedynie charakter informacyjny.
- Nie zaleca się montażu większej liczby opraw ulicznych niż 4 szt/słup o masie pojedynczej oprawy 10kg i powierzchni bocznej 0,1m² przy równoczesnym spełnianiu warunków zawartych w tabeli.
- Dobre fundamenty dostosowane są do maksymalnego danego obciążenia słupa/masztu, przy zamontowaniu opraw/naświetlaczy o parametrach zawartych w tabeli.
- Dla słupów stożkowych klasa obciążenia konstrukcji "B", dla słupów rurowych typu SRN klasa obciążenia konstrukcji "A".
- Średnica ośmiokąta to średnica okręgu opisanego.
- Powierzchnie wiatrowe wyznaczone dla C_x=1,0 i terenu kat. 2.

- Polygonal poles from 6 m high are made of steel type S355.
- Areas are provided for information purposes only.
- It is not recommended to install more than 4 pcs. of street luminaires / pole with a weight of a single luminaire 10 kg and a side area of 0.1 m², while meeting the conditions contained in the table.
- The selected foundations are adjusted to the maximum load of the column / mast, with the installation of luminaires / floodlights with the parameters included in the table.
- For conical columns - the construction load class "B", for tubular columns type SRN - the load class "A".
- The diameter of the octagon is the diameter of the circumscribed circle.
- Wind surfaces were determined for C_x = 1.0 and terrain cat. 2.

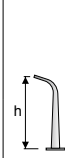
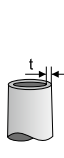
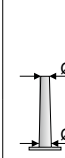
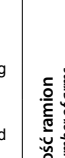
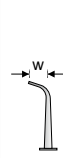
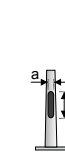
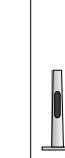
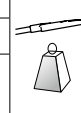

Typ Type	Przekrój Profile	 [m]	 [mm]	 [mm]	Ilość ramion Number of arms	 [mm]	 [mm]	 [mm]		maksymalna powierzchnia wiatrowa [m ²] max wind area				
										strefa wiatrowa / wind zone				
										do 300 m n.p.m.	do 300 m n.p.m.	do 450 m n.p.m.		
ZETA 5/1/1 CN 4/2,5/60/F160+W16/1/1/1-60/10	⊙	5	2,5	60/105	1	1000	70x400	500	D16/100	0,15	0,06	0,10	10	37
ZETA 5/1/1,5 CN 4/2,5/60/F160+W16/1/1/1,5-60/10	⊙	5	2,5	60/105	1	1500	70x400	500	D16/100	0,07	-	0,04	10	39
ZETA 5/2/1 CN 4/2,5/60/F160+W16/1/2/1-60/10/180	⊙	5	2,5	60/105	2	1000	70x400	500	D16/100	0,29	0,11	0,19	20	43
ZETA 5/2/1,5 CN 4/2,5/60/F160+W16/1/2/1,5-60/10/180	⊙	5	2,5	60/105	2	1500	70x400	500	D16/100	0,22	0,04	0,12	20	47
ZETA 6/1/1 CN 5/2,5/60/F160+W16/1/1/1-60/10	⊙	6	2,5	60/116	1	1000	85x400	500	D16/100	0,09	-	0,06	10	45
ZETA 6/1/1,5 CN 5/2,5/60/F160+W16/1/1/1,5-60/10	⊙	6	2,5	60/116	1	1500	85x400	500	D16/100	0,04	-	-	10	47
ZETA 6/2/1 CN 5/2,5/60/F160+W16/1/2/1-60/10/180	⊙	6	2,5	60/116	2	1000	85x400	500	D16/120	0,14	-	0,06	20	51
ZETA 6/2/1,5 CN 5/2,5/60/F160+W16/1/2/1,5-60/10/180	⊙	6	2,5	60/116	2	1500	85x400	500	D16/120	0,07	-	-	20	55
ZETA 7/1/1 CN 6/3/60/F160+W16/1/1/1-60/10	⊙	7	3	60/127	1	1000	85x400	500	D16/120	0,20	0,09	0,14	15	55
ZETA 7/1/1,5 CN 6/3/60/F160+W16/1/1/1,5-60/10	⊙	7	3	60/127	1	1500	85x400	500	D16/120	0,13	0,04	0,08	15	57
ZETA 7/2/1 CN 6/3/60/F160+W16/1/2/1-60/10/180	⊙	7	3	60/127	2	1000	85x400	500	D16/120	0,27	0,08	0,17	30	60
ZETA 7/2/1,5 CN 6/3/60/F160+W16/1/2/1,5-60/10/180	⊙	7	3	60/127	2	1500	85x400	500	D16/120	0,21	-	0,10	30	65
ZETA 8/1/1 CN 7/3/60/F160+W16/1/1/1-60/10	⊙	8	3	60/138	1	1000	85x400	500	D16/120	0,23	0,10	0,16	15	66
ZETA 8/1/1,5 CN 7/3/60/F160+W16/1/1/1,5-60/10	⊙	8	3	60/138	1	1500	85x400	500	D16/120	0,15	0,05	0,09	15	68
ZETA 8/2/1 CN 7/3/60/F160+W16/1/2/1-60/10/180	⊙	8	3	60/138	2	1000	85x400	500	D16/120	0,25	0,06	0,14	30	71
ZETA 8/2/1,5 CN 7/3/60/F160+W16/1/2/1,5-60/10/180	⊙	8	3	60/138	2	1500	85x400	500	D16/120	0,19	-	0,08	30	76
ZETA 9/1/1 CN 8/3/60/F160+W16/1/1/1-60/10	⊙	9	3	60/149	1	1000	85x400	500	D16/120	0,24	0,10	0,16	15	78
ZETA 9/1/1,5 CN 8/3/60/F160+W16/1/1/1,5-60/10	⊙	9	3	60/149	1	1500	85x400	500	D16/120	0,15	0,05	0,09	15	80
ZETA 9/2/1 CN 8/3/60/F160+W16/1/2/1-60/10/180	⊙	9	3	60/149	2	1000	85x400	500	D16/140	0,23	0,04	0,12	30	83
ZETA 9/2/1,5 CN 8/3/60/F160+W16/1/2/1,5-60/10/180	⊙	9	3	60/149	2	1500	85x400	500	D16/140	0,16	-	0,05	30	88
ZETA 10/1/1 CN 9/3/60/F160+W16/1/1/1-60/10	⊙	10	3	60/160	1	1000	85x400	500	D16/140	0,24	0,09	0,15	15	90
ZETA 10/1/1,5 CN 9/3/60/F160+W16/1/1/1,5-60/10	⊙	10	3	60/160	1	1500	85x400	500	D16/140	0,17	0,04	0,10	15	92
ZETA 10/2/1 CN 9/3/60/F160+W16/1/2/1-60/10/180	⊙	10	3	60/160	2	1000	85x400	500	D16/140	0,19	-	0,09	30	95
ZETA 10/2/1,5 CN 9/3/60/F160+W16/1/2/1,5-60/10/180	⊙	10	3	60/160	2	1500	85x400	500	D16/140	0,13	-	-	30	100

⊙ - stożek / round-conical

- Słupy wielokątne od 6m wysokości wykonywane są ze stali S355.
 - Podane powierzchnie mają jedynie charakter informacyjny.
 - Nie zaleca się montażu większej liczby opraw ulicznych niż 4 szt/słup o masie pojedynczej oprawy 10kg i powierzchni bocznej 0,1m² przy równoczesnym spełnianiu warunków zawartych w tabeli.
 - Dobre fundamenty dostosowane są do maksymalnego danego obciążenia słupa/masztu, przy zamontowaniu opraw/naświetlaczy o parametrach zawartych w tabeli.
 - Dla słupów stożkowych klasa obciążenia konstrukcji "B", dla słupów rurowych typu SRN klasa obciążenia konstrukcji "A".
 - Średnica ośmiokąta to średnica okręgu opisanego.
 - Powierzchnie wiatrowe wyznaczono dla C_x=1,0 i terenu kat. 2.
- Polygonal poles from 6 m high are made of steel type S355.
 - Areas are provided for information purposes only.
 - It is not recommended to install more than 4 pcs. of street luminaires / pole with a weight of a single luminaire 10 kg and a side area of 0.1 m², while meeting the conditions contained in the table.
 - The selected foundations are adjusted to the maximum load of the column / mast, with the installation of luminaires / floodlights with the parameters included in the table.
 - For conical columns -the construction load class "B", for tubular columns type SRN - the load class "A".
 - The diameter of the octagon is the diameter of the circumscribed circle.
 - Wind surfaces were determined for C_x = 1.0 and terrain cat. 2.

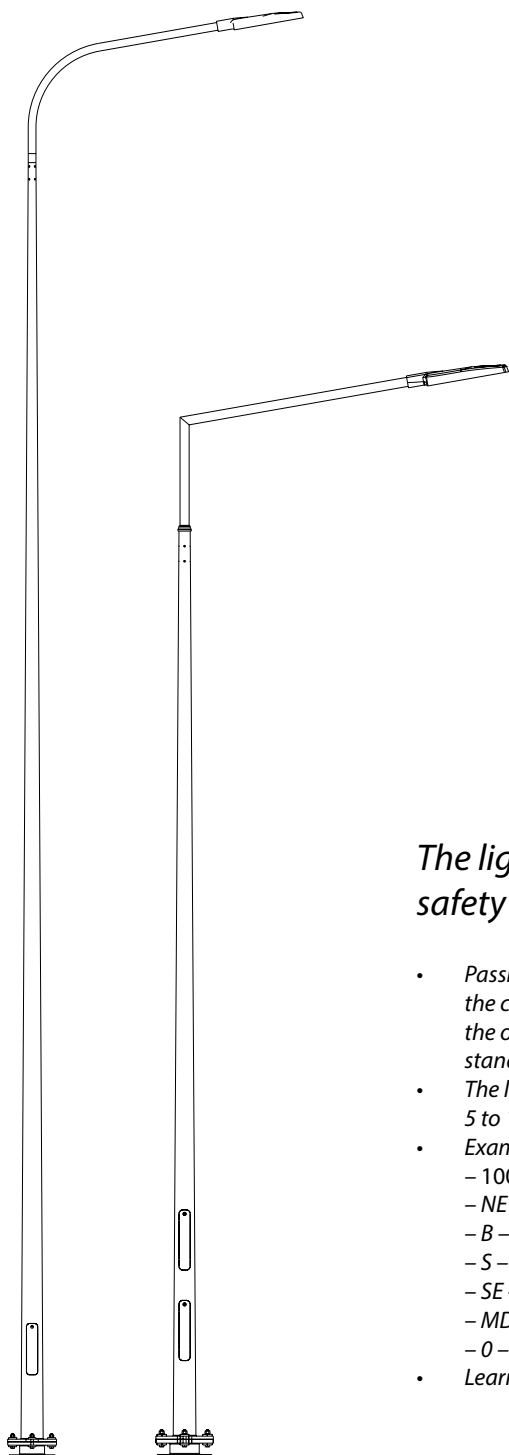

Słupy oświetleniowe z cechami bezpieczeństwa biernego 100NE B, 70NE B, 50NE B

- Bierne bezpieczeństwo konstrukcji wsporczych jest to zagadnienie, które opisuje zachowanie się słupa oświetleniowego w przypadku uderzenia pojazdu w konstrukcję. Sposób przeprowadzenia badań i analizy otrzymanych wyników pozwalają opisać badany słup oświetleniowy parametrami zgodnie z normą EN 12767.
- Słupy z cechami bezpieczeństwa biernego w kategorii 100NE B, 70NE B, 50NE B w zakresie wysokości od 5 do 12 m z wysięgnikami.
- Oznaczenie konstrukcji wsporczej jako 100/70/50-NE-B-S-SE-MD-0 wg EN 12767:2019
 - 100/70/50 – klasa prędkości
 - NE – kategoria pochłaniania energii
 - B – poziom bezpieczeństwa użytkownika pojazdu
 - S – standardowy grunt posadowienia słupa
 - SE – po uderzeniu trzon słupa odłącza się od podstawy
 - MD – uderzenie w słup z wielu kierunków
 - 0 – niewielkie ryzyko deformacji dachu
- Więcej informacji na stronie www.slupybezpieczne.pl

The lighting poles with passive safety attributes 100NE B, 70NE B, 50NE B

- *Passive safety of support structures is an issue that describes the behavior of the lighting pole in the case of a vehicle impact on the structure. The method of carrying out the test and analysis of the obtained results allows to describe the tested lighting pole with parameters according to the standard EN 12767.*
- *The lighting poles with passive safety in the category 100NE B, 70NE B, 50NE B in the height range 5 to 12 m with brackets.*
- *Example of description of supporting structure 100/70/50-NE-B-S-SE-MD-0 wg EN 12767:2019*
 - 100/70/50 – speed class
 - NE – category of energy absorption
 - B – the safety level of the vehicle user
 - S – backfill type S, standard aggregates
 - SE – Separation collapse mode
 - MD – Multi-directional
 - 0 – low roof indentation
- *Learn more on www.slupybezpieczne.pl*

Słupy stożkowe typu "C" z jedną wnęką rewizyjną lub dwiema wnękami rewizyjnymi, zakres wysokości 5m - 12m, o grubości ścianek 3 mm i 4 mm, średnice górne fi 60 i fi76, fundamenty z rozstawem kotew 190 mm i 250 mm.

"C" type conical columns with one inspection recess or two inspection recesses, height range 5m-12m, wall thickness 3 mm and 4 mm, upper diameters 60 and 76 mm, foundations with anchor spacing 190 mm and 250 mm.

Słupy stożkowe typu "CN" z jedną wnęką rewizyjną, zakres wysokości 5m - 12m, o grubości ścianek 3 mm i 4 mm, średnice górne fi 60 i fi76, fundamenty z rozstawem kotew 190 mm i 250 mm
Szczegółowe zestawienie na stronie www.slupybezpieczne.pl

"CN" type conical columns with one inspection recess, height range 5m-12m, wall thickness 3 mm and 4 mm, upper diameters 60 and 76 mm, foundations with anchor spacing 190 mm and 250 mm.
A detailed list is available at www.slupybezpieczne.pl

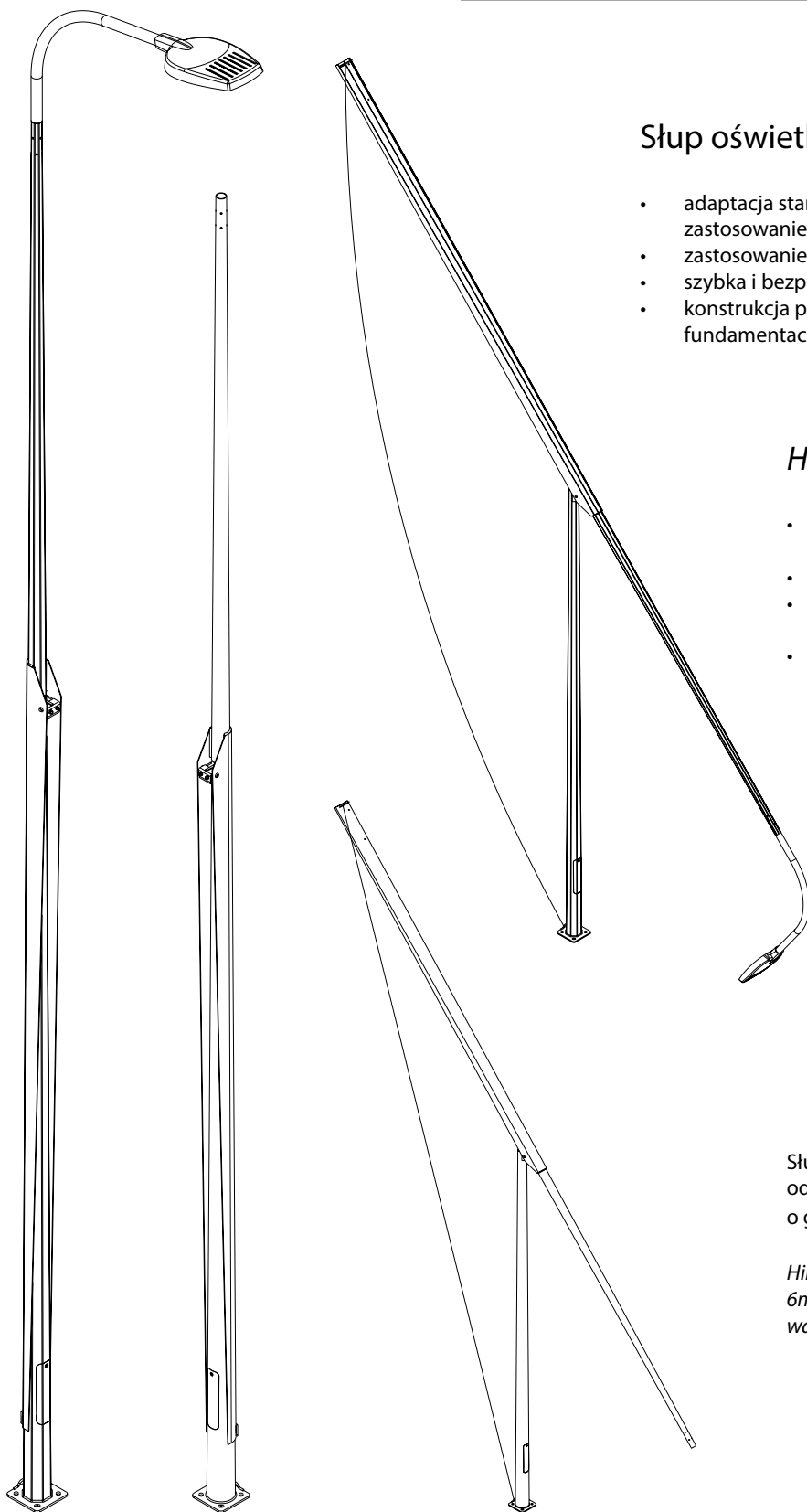

Słup oświetleniowy - przegubowy

- adaptacja standardowych słupów typu SX, SO oraz CN poprzez zastosowanie węzła przegubowego
- zastosowanie w miejscach nietypowych i trudno dostępnych
- szybka i bezpieczna wymiana źródła światła lub jego przegląd
- konstrukcja przeznaczona do montażu na standardowych fundamentach

Hinged lighting pole

- *adaptation of standard poles type SX, SO and CN through the use of an hinge joint*
- *application in non-standard and inaccessible places*
- *quick and safe replacement of the light source or its inspection*
- *structure designed to be mounted on standard foundations*











Słupy przegubowe oferowane są w zakresie wysokości od 6m do 12m, o przekroju wielokątnym lub okrągłym o grubościach ścianek 3mm lub 4mm.

Hinged lighting poles are offered in heights ranging from 6m up to 12m, with polygonal or round cross-sections and wall thicknesses of 3mm or 4mm.

Słup w pozycji pionowej.
Pole in vertical position.

Parametry techniczne pokazanej oprawy typu Tweet zawarte są w katalogu „Oprawy Oświetleniowe” firmy ELMONTER. Słupy przegubowe są każdorazowo projektowane w zależności od zastosowanej oprawy oświetleniowej i wysięgnika/belki. Bardzo ważnym parametrem, decydującym o konstrukcji słupa przegubowego, jest waga zastosowanej oprawy oświetleniowej.

Technical parameters of the shown Tweet luminaire are included in the ELMONTER's "Lighting Fixtures" catalog. Hinged columns are each time designed in depends on applied lighting fixture and bracket/beam. Very important parameter which determines whole the structure of the hinged column, is the weight of the luminaire.

Typ Type	Przekrój Profile	 [m]	 [mm]	 g/d [mm]	 a x b [mm]	 [mm]		maksymalna powierzchnia wiatrowa [m ²] max wind area				M [kNm]	T [kN]	
								strefa wiatrowa / wind zone						
								 do 300 m n.p.m.	 do 300 m n.p.m.	 do 450 m n.p.m.				
MN 10/4/F220	○	10	4	103/232	100x400	500	D22/180	1,69	0,96	1,25	50	24,48	3,32	179
MS 10/4/F250	○	10	4	103/290	100x400	500	B200	2,15	1,24	1,63	150	32,43	3,76	212
MW 10/4/F400	○	10	4	130/340	120x500	500	F5/K-400	3,5	2,76	2,83	200	66,53	6,93	315
MN 11/4/F220	○	11	4	103/232	100x400	500	D22/180	1,36	0,9	1,08	50	24,48	3,32	196
MS 11/4/F250	○	11	4	103/290	100x400	500	B200	1,72	0,9	1,27	150	32,43	3,76	232
MN 12/4/F220	○	12	4	103/232	100x400	500	D22/180	1,06	0,46	0,74	50	24,48	3,32	213
MST 12/4/F250	○	12	4	103/240	100x500	500	B-200	1,41	0,85	1,1	150	34,8	4,71	216
MS 12/4/F250	○	12	4	103/290	100x400	500	B200	1,35	0,6	0,94	150	32,43	3,76	252
MW 12/4/F400	○	12	4	130/340	120x500	500	F5/K-400	3,5	2,76	2,83	200	66,53	6,93	364
MS 14/4/F250/E	○	14	4	103/288	100x400	500	B200	1,00	0,30	0,59	150	49	4,9	297
MS 14/4/F300	○	14	4	103/330	120x500	500	F2	2,73	1,46	1,97	150	65,7	6,57	351
MST 14/4/F300	○	14	4	103/280	120x500	500	F-1	1,45	0,82	1,11	150	43	5,27	309
MW 14/4/F400	○	14	4	130/400	160x500	500	F5-1/16	3,81	2,5	3,05	200	88,82	8,31	475
MS 16/4/F400	○	16	4	103/385	120x500	500	F5-1/16	2,91	1,45	2,03	150	94,4	9,44	486
MST 16/4/F300	○	16	4	103/335	130x500	500	F-2	1,9	1,01	1,41	150	60,5	6,64	390
MW 16/4/F400	○	16	4	130/435	160x500	500	F5-1/16	4,42	2,96	3,61	200	125,1	10,64	568
MS 18/4/F400	○	18	4	103/435	120x500	500	F5-1/16	2,66	1,11	1,71	150	110	11,11	571
MST 18/4/F400	○	18	4	103/360	140x500	500	F-5/1-16	1,7	0,85	1,21	150	70,6	7,23	474
MW 18/4/F500	○	18	4	130/475	160x500	500	F275/75/50	4,27	2,75	3,42	200	144,89	11,47	735
MS 20/4/F400	○	20	4	103/460	120x500	500	F5-1/16	2,6	1,17	1,71	150	130,8	13,8	657
MST 20/4/F400	○	20	4	103/360	140x500	500	f-5/1-16	1,24	0,51	0,85	150	73,2	7,4	563
MW 20/4/KK	○	20	4	130/515	160x500	500	kosz kotwowy / anchor basket 16M24 S355 L=1000 Ø 680	4,1	2,57	3,15	200	166,69	12,32	756
MW 21/4/KK	○	21	4	230/750	500x200	500	kosz kotwowy / anchor basket M30 S355 L=1000 Ø 680	11,03	7,02	8,85	200	445,64	26,45	1210
MST 22/4/F400	○	22	4	103/420	160x500	500	F-5/1-16	0,82	0,3	0,54	150	89	8,61	642
MW 22/4/KK	○	22	4	230/750	500x200	500	kosz kotwowy / anchor basket M30 S355 L=1000 Ø 680	10,11	6,36	8,08	200	436,72	25,56	1252
MW 23/4/KK	○	23	4	230/750	500x200	500	kosz kotwowy / anchor basket M30 S355 L=1000 Ø 680	8,89	5,57	7,03	200	427,99	24,95	1304
MST 24/4/F400	○	24	4	103/450	160x500	500	F-5/1-16	0,85	0,3	0,54	150	106,7	10,1	726
MW 24/4/KK	○	24	4	230/750	500x200	500	kosz kotwowy / anchor basket M30 S355 L=1000 Ø 680	8,00	4,93	6,28	200	419,43	23,69	1355
MW 25/4/KK	○	25	4	230/750	500x200	500	kosz kotwowy / anchor basket M30 S355 L=1000 Ø 680	7,56	4,61	5,91	200	411,04	23,51	1404







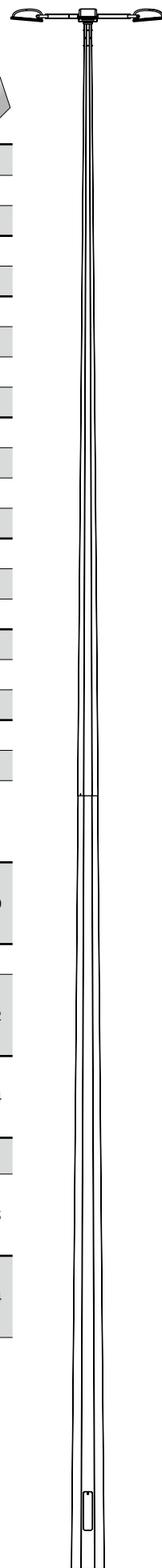

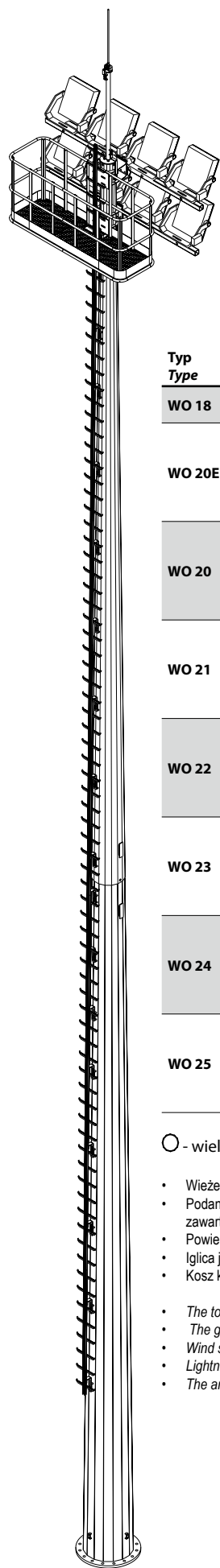
○ – wielokąt / polygon

- Maszty wykonywane są ze stali S355
- Podane powierzchnie są maksymalnymi powierzchniami przewidzianymi dla typowych rozwiązań, w celu zamontowania konstrukcji przekraczających parametry zawarte w tabeli prosimy o kontakt
- Zastosowanie fundamentów prefabrykowanych do masztów należy każdorazowo zweryfikować w oparciu o wyniki analizy gruntu
- Powierzchnie wiatrowe wyznaczone dla $C_x=1,0$ i terenu kat. 2
- Kosz kotwowy nie stanowi pełnego zbrojenia fundamentu. Projekt fundamentu leży po stronie klienta.

- Masts are made of steel type S355.
- The given areas are the maximum areas provided for typical solutions, in order to install structures exceeding the parameters contained in the table, please contact us.
- The use of prefabricated foundations for masts should be verified each time based on the results of the soil analysis.
- Wind surfaces were determined for $C_x = 1.0$ and terrain cat. 2.
- The anchor basket does not constitute a full reinforcement of the foundation. The design of the foundation is the responsibility of the customer.





Typ Type	 [m]	 [mm]	 g/d [mm]	 a x b [mm]	 [mm]	 [mm]		maksymalna powierzchnia wiatrowa [m ²] max wind area				M [kNm]	T [kN]			
								strefa wiatrowa / wind zone							[kg]	[kg]
								I do 300 m n.p.m.	II do 300 m n.p.m.	III do 450 m n.p.m.						
WO 18	18	4	130/475	160x500x2	500	300	F275/75/50	2,41	0,89	1,56	200	144,89	11,47	1074		
WO 20E	20	4	130/515	160x500x2	500	200	Kosz kotwowy / anchor basket 16M24 L=1000 Ø 680	2,24	0,71	1,29	200	166,69	12,32	1106		
WO 20	20	4	230/750	200x500x2	500	300	Kosz kotwowy / anchor basket 16M30 L=1000mm Ø 955	10,09	5,81	7,77	200	454,73	27,44	1691		
WO 21	21	4	230/750	200x500x2	500	300	Kosz kotwowy / anchor basket 16M30 L=1000mm Ø 955	9,17	5,16	6,99	200	445,64	26,45	1745		
WO 22	22	4	230/750	200x500x2	500	300	Kosz kotwowy / anchor basket 16M30 L=1000mm Ø 955	8,25	4,5	6,22	200	436,73	25,56	1803		
WO 23	23	4	230/750	200x500x2	500	300	Kosz kotwowy / anchor basket 16M30 L=1000mm Ø 955	7,03	3,71	5,17	200	427,99	24,95	1854		
WO 24	24	4	230/750	200x500x2	500	300	Kosz kotwowy / anchor basket 16M30 L=1000mm Ø 955	6,14	3,07	4,42	200	419,43	23,69	1914		
WO 25	25	4	230/750	200x500x2	500	300	Kosz kotwowy / anchor basket 16M30 L=1000mm Ø 955	5,7	2,75	4,05	200	411,04	23,51	1968		

○ - wielokąt / polygon

- Wieże wykonywane są ze stali S355
- Podane powierzchnie są maksymalnymi powierzchniami przewidzianymi dla typowych rozwiązań, w celu zamontowania konstrukcji przekraczających parametry zawarte w tabeli prosimy o kontakt telefoniczny
- Powierzchnie wiatrowe wyznaczono dla $C_x=1,0$ i terenu kat. 2
- Iglica jest wyposażeniem opcjonalnym
- Kosz kotwowy nie stanowi pełnego zbrojenia fundamentu. Projekt fundamentu leży po stronie klienta.

- The towers are made of steel type S355 .
- The given areas are the maximum areas provided for typical solutions, in order to install structures exceeding the parameters included in the table, please contact us by phone.
- Wind surfaces were determined for $C_x = 1.0$ and terrain cat. 2.
- Lightning rod is optional equipment
- The anchor basket does not constitute a full reinforcement of the foundation. The design of the foundation is the responsibility of the customer.

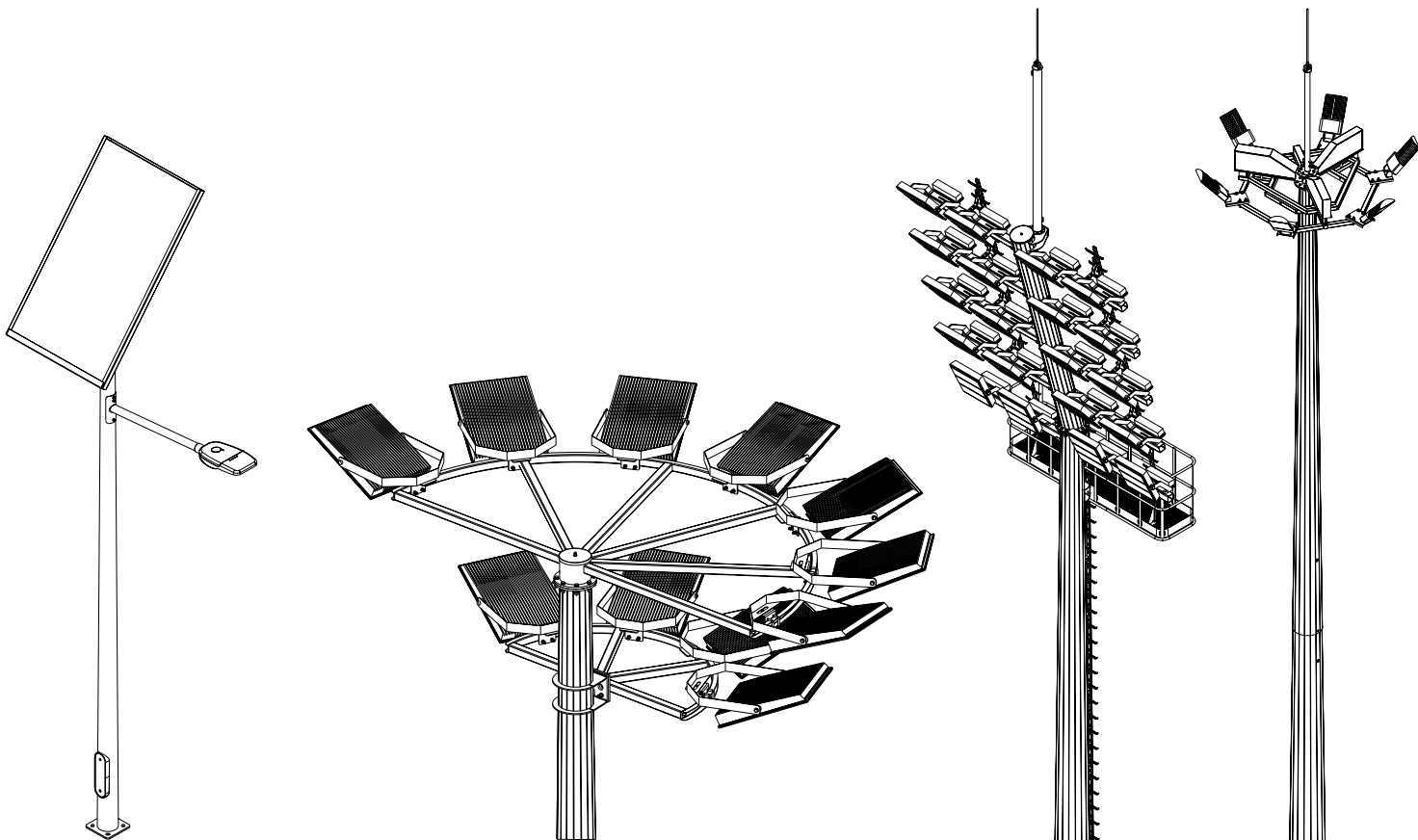

Wieże oświetleniowe

- stalowe wieże przeznaczone do oświetlenia obiektów sportowych, przemysłowych i infrastrukturalnych
- w zależności od wysokości i średnicy oferowane z systemem komunikacyjnym wewnętrznym i zewnętrznym
- trzon wieży składa się z odcinków co ułatwia transport i montaż
- każdorazowo wytwarzane według indywidualnego projektu, uzgodnień z inwestorem oraz strefy wiatrowej
- konstrukcja zabezpieczona antykorozyjnie poprzez cynkowanie ogniowe lub w systemie duplex – cynkowanie ogniowe + malowanie systemem malarskim
- iglica jest wyposażeniem opcjonalnym

Lighting towers

- *steel towers for illuminating sports, industrial and infrastructural facilities*
- *depending on their height and diameter, they are offered together with internal and external communication systems*
- *the tower shaft consists of detachable sections, which facilitates transport and installation*
- *each structure is made according to a custom design, arrangements with the investor and the wind zone*
- *structure made corrosion-proof by hot-dip zinc coating or duplex system - hot-dip zinc coating and painting*
- *lightning rod is optional equipment*

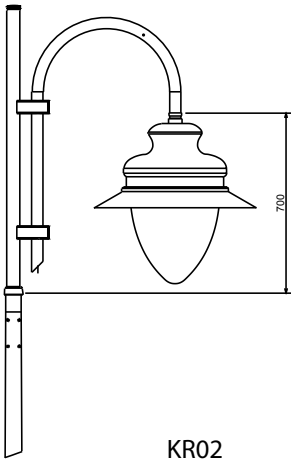

KR02

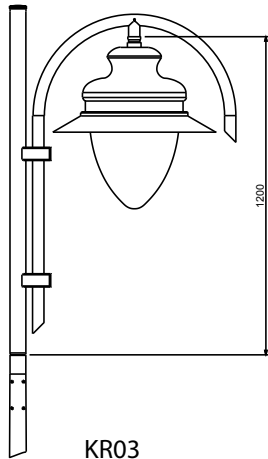

KR03

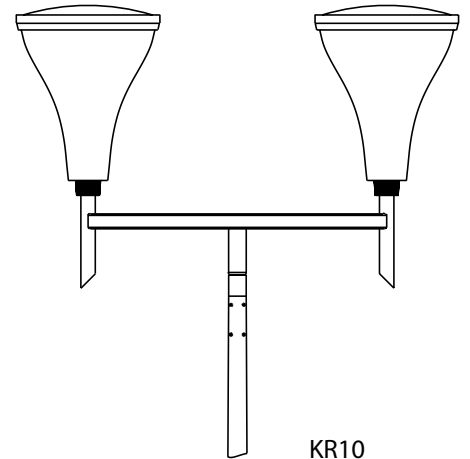

KR10

Przykład oznaczenia / Marking example

KR02/2-60

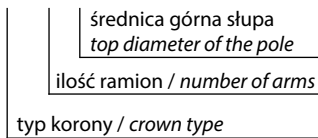

Można zastosować różne końcówki montażowe opraw.
Various mounting fittings can be used.

Typ korony Crown type	Ilość ramion Number of arms			Słup Pole	Słup Pole
	1	2	3	Ø 60	Ø 76
KR02	✓	✓	✓	✓	✓
KR03	✓	✓	✓	✓	✓
KR07		✓		✓	✓
KR10		✓	✓	✓	✓

Parametry techniczne pokazanych opraw typu Netta oraz Buzz zawarte są w katalogu „Oprawy Oświetleniowe” firmy ELMONTER.

Specifications of shown luminaires Netta and Buzz are included in the Elmonter catalogue of “Lighting fixtures”.

Brackets / Wyświetniki

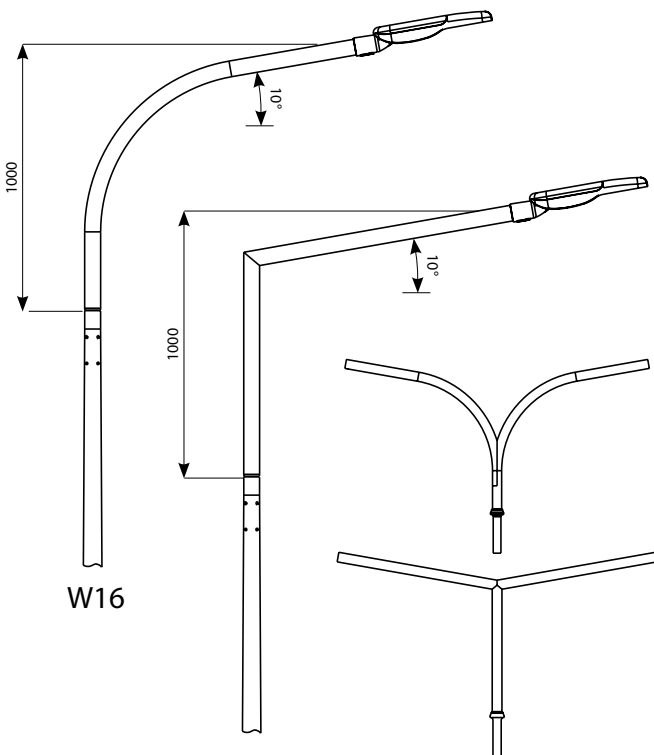

W16

W20

Wyświetnik 2-ramienny
Double arm bracket

Przykład oznaczenia / Marking example

W20/1/2/1,5-60/10/180

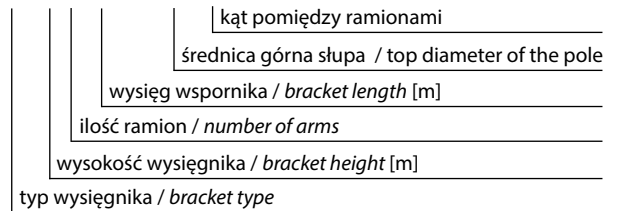



Typ wysięgnika Bracket type	Maksymalna ilość ramion Maximum number of arms		kąt		wysokość		Ø 60
	Ø 60 / Ø 76 / Ø 89	Ø 89 / Ø 103	0,5-2 m	0,2 m	1 m	2 m	
W16	1-4	4	✓		✓	✓	✓
W20	1-4	6	✓	✓	✓	✓	✓

Dobór należy skonsultować z firmą Elmonter.
The selection should be consulted with company Elmonter.

Parametry techniczne pokazanych opraw typu Avatar zawarte są w katalogu „Oprawy Oświetleniowe” firmy ELMONTER.
*Sposób montażu wysięgników podano na stronie 21.

Specifications of shown luminaires Avatar are included in the Elmonter catalogue of “Lighting fixtures”.
*The method of mounting the brackets is given on page 21.



Typ Type	h [m]		
			[kg]
SKO 8	8	F220	103,1
SKO 9	9	F220	115,6
SKO 10	10	F220	128,3
SKO 11	11	F220	140,9
SKO 12	12	F220	153,4
SKO 13	13	B-200	234
SKO 15	15	F-1	324
SKO 17	17	F-2	404,5
SKO 19	19	F-5/1-16	489,5
SKO 21	21	F-5/1-16	567,1
SKO 23	23	F-5/1-16	662,5
SKO 25	25	F-5/1-16	746,6
SKO 26	26	F275/75/50	795
SKO 28	28	kosz kotwowy / anchor basket	1185
SKO 32	32	kosz kotwowy / anchor basket	1485
SKO 36	36	kosz kotwowy / anchor basket	2252

- Ochrona odgromowa wg PN-EN 62305-1-4
- Obciążenie wiatrem wg PN-EN 1991-1-4 dla kat. terenu II, strefa wiatrowa I, II i III do 600 m n.p.m
- Kosz kotwowy nie stanowi pełnego zbrojenia fundamentu. Projekt fundamentu leży po stronie klienta.
- Iglica odgromowa spełnia wymagania norm PN-EN 50164-1, PN-EN 50164-2
- Konstrukcje wykonane ze stali S235, S355 wg PN-EN 10025
- Wymiary i tolerancje zgodnie z PN-EN 1090
- Ochrona antykorozyjna – cynkowanie ogniowe wg PN-EN ISO 1461
- Istnieje możliwość wykonania dowolnej wysokości wg uzgodnień
- Wysokość podana jest z iglicą

- *Lightning protection according to PN-EN 62305-1-4*
- *Wind load according to PN-EN 1991-1-4, standard for a terrain category II, wind zone I, II and III up to 600 m above sea level*
- *The anchor basket does not constitute a full reinforcement of the foundation. The design of the foundation is the responsibility of the customer.*
- *Spire lightning meets the requirements of standards PN-EN 50164-1, PN-EN 50164-2*
- *The constructions are made of steel S235, S355 according to PN-EN 10025*
- *Dimensions and tolerances according to PN-EN 1090*
- *Rustproof protection – hot dip galvanized according to PN-EN ISO 1461*
- *It is possible to make any height according to the arrangements*
- *Height given with the lightning rod*

Belki i Głowice

Przedstawione konstrukcje mają jedynie charakter poglądowy i nie wyczerpują pełnej informacji na temat wszystkich oferowanych przez firmę rozwiązań.

Beams and heads

The designs are for illustration only and do not cover the full information on all the solutions offered by the company.

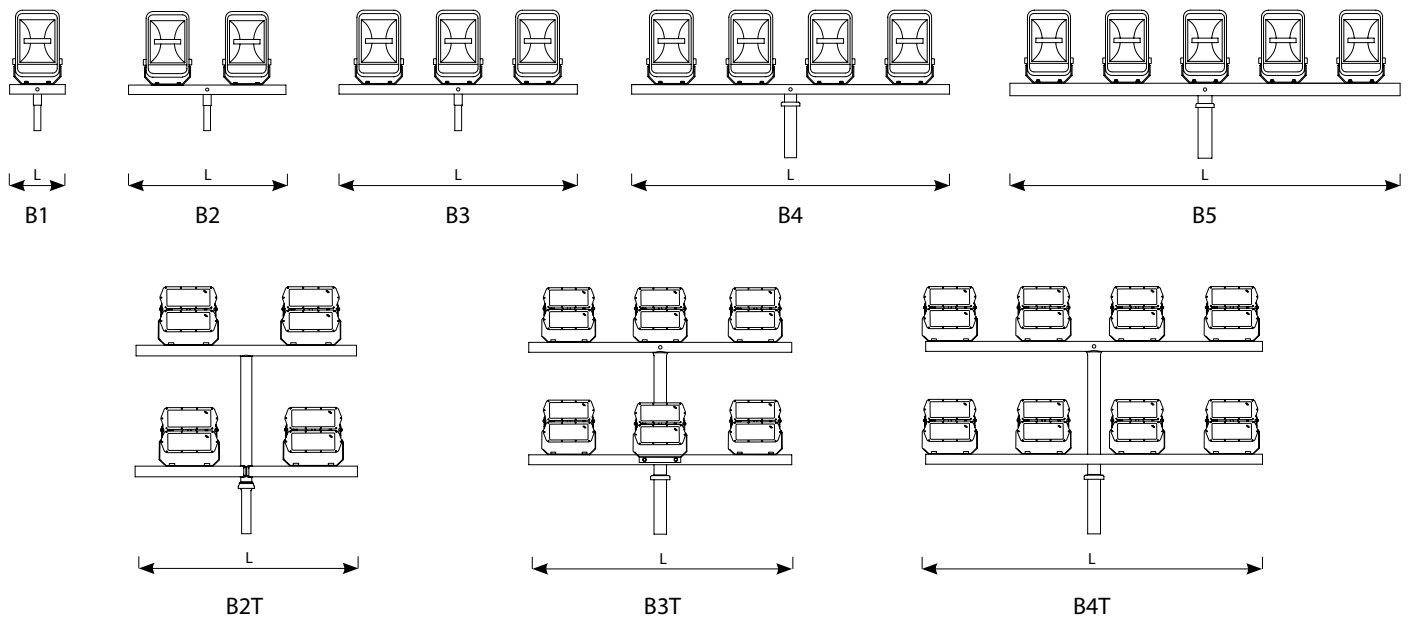

Sposoby montażu Mounting options

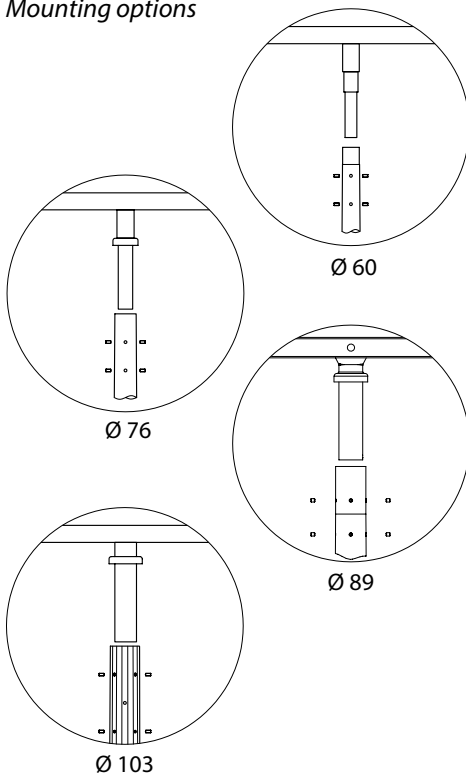

Typ belki Beam type	Ilość projektorów Number of projectors	L	Ø 60	Ø 76	Ø 89	Ø 103	Ø 130
B1	1	350	✓	✓	✓	✓	✓
B2	2	1000	✓	✓	✓	✓	✓
B3	3	1500	✓	✓	✓	✓	✓
B4	4	2000		✓	✓	✓	✓
B5	5	2500			✓	✓	✓
B2T	4	1200	✓	✓	✓	✓	✓
B3T	6	1600		✓	✓	✓	✓
B4T	8	2000			✓	✓	✓

Przykład oznaczenia / Marking example

B1/350 – 60

końcówka słupa/masztu / top diameter of the pole/mast
 długość / length
 typ belki / beam type

Śruby dociskowe dostarczane razem ze słupem.
 Grub screws supplied with the pole.

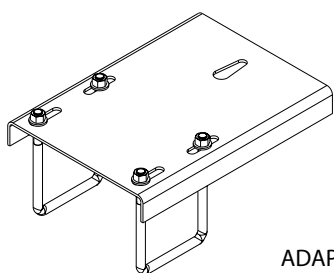

ADAPTER UNI

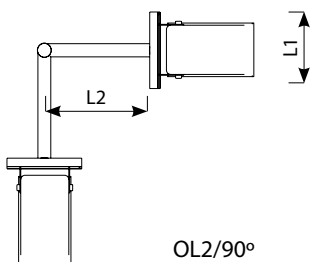

OL2/90°

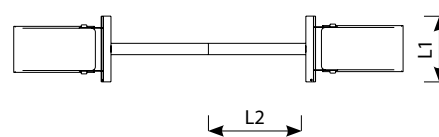

OL2/180°

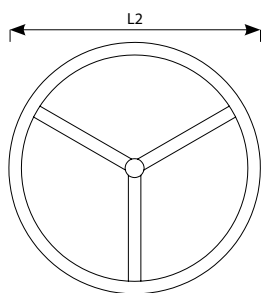

OR/800

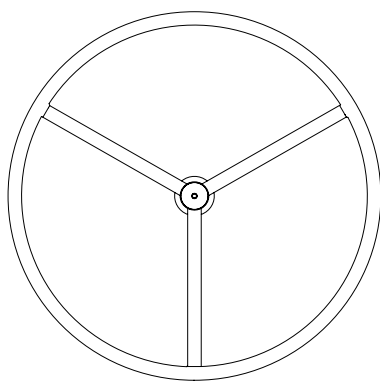

OR/1100

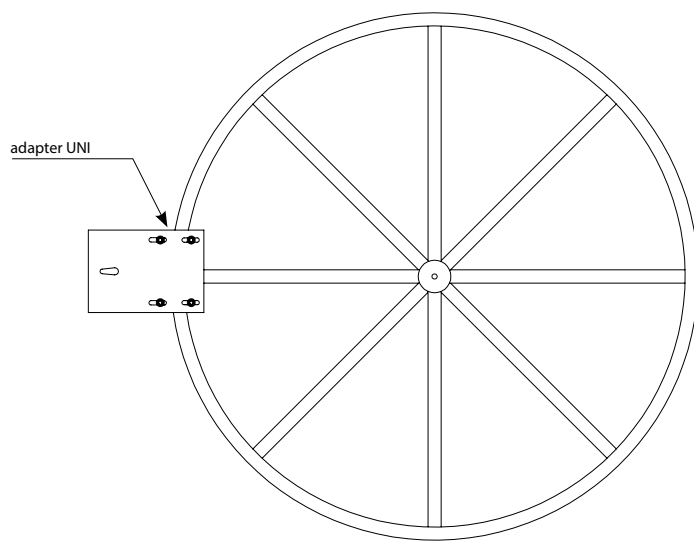

OR/1600

Przykład oznaczenia / Marking example

OL2/350-103/90

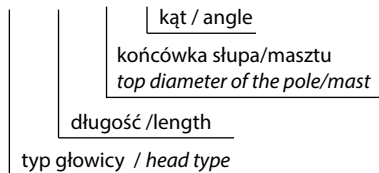

Typ głowicy Head type	Ilość projektorów Number of projectors	L1	L2	Ø 60	Ø 76	Ø 89	Ø 103	Ø 130
OL2/180°	2	350	500	✓	✓	✓	✓	✓
OL2/90°	2	350	500	✓	✓	✓	✓	✓
OR/800	3	-	Ø 800	✓	✓	✓	-	-
OR/1100	6	-	Ø 1100	-	✓	✓	✓	✓
OR/1600	8	-	Ø 1600	-	-	✓	✓	✓

Ilość naświetlaczy oraz ich rozmieszczenie na głowicy powinno zabezpieczać stabilność konstrukcji. Możliwa jest realizacja zamówień na głowice wg indywidualnych lub nietypowych projektów. Po cynkowaniu istnieje możliwość malowania proszkowego.

The number of floodlights and their arrangement on the head should ensure stability of the construction. We accept orders for individually designed or non-standard heads. After galvanization the product may be powder coated.



Fundamenty

Fundations

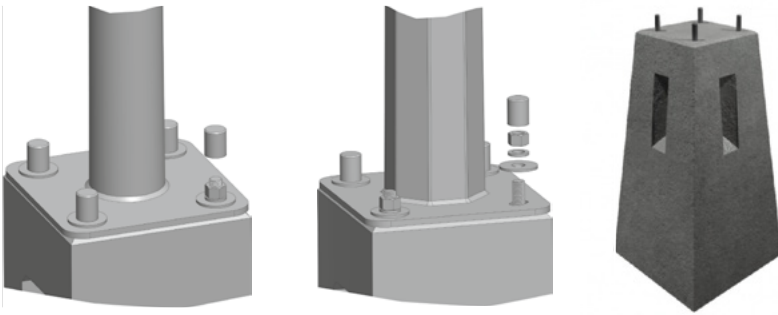

Montaż słupa do fundamentu / Pole mounting on the foundation

Fundament Foundation	A	B [mm]	C [mm]	H [mm]	Waga fundamentu Weight of the foundation [kg]
D16/100	4xM20	160	260	1000	127
D16/120	4xM20	160	260	1200	149
D16/140	4xM20	160	260	1400	172
D16/160	4xM20	160	260	1600	196
D22/150	4xM24	220	340	1500	274
D22/180	4xM24	220	340	1800	325
F100	4xM20	190	290	1000	130
B120	4xM24	250	350	1200	270
B150	4xM24	250	350	1500	270
B200	4xM24	250	400	2000	570
F1	4xM27	300	800	1650	900
F2	4xM33	300	850	1700	1150
F5	4xM33	300	900	1500	1900
F5/K-300	4xM33	300	900	1500	1000
F5/K-400	4xM33	400	900	1500	1000
F5/1	4xM33	400	900	2000	1900
F5/1-16	4xM33	400	1050	2500	2700
F5/1-18	4xM33	400	1050	2750	2950
F275/75/50	4xM39	500	1100	2750	3850

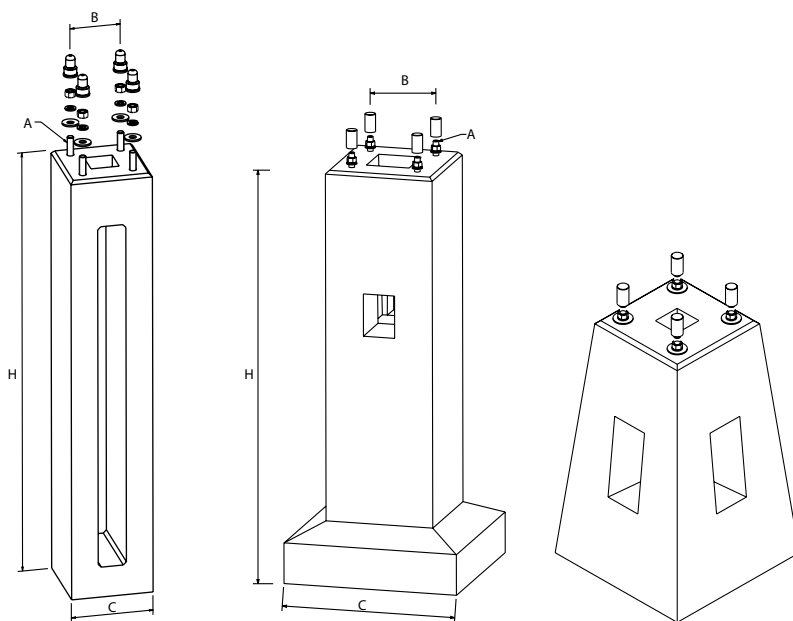

Elmonter-Oświetlenie posiada w swojej ofercie fundamenty do posadawiania słupów oświetleniowych i masztów, które spełniają wymagania co do warunków wytrzymałościowych (maksymalny moment utwierdzenia M, który można przyłożyć do głowicy fundamentu). Wartość momentu M zależy od wymiarów fundamentu, rodzaju i właściwości gruntu, w którym ten fundament jest osadzony.

Obliczenia nośności gruntu dla fundamentów przeprowadzono na podstawie normy PN-80/B-03322. Przedstawione fundamenty są wykonane jako standardowe dla średniej klasy gruntu (grunt niespoisty, obliczeniowy kąt tarcia wewnętrznego gruntu $\phi=30^\circ$, obliczeniowa gęstość objętościowa gruntu $\gamma_D=17\text{kN/m}^3$). Ostateczny dobór fundamentów należy do projektanta po zapoznaniu się z warunkami gruntowymi.

Głębokość posadawienia słupów bezpośrednio wkopywanych w ziemię podana jest w normie PN-EN 40-2 i zależy od wysokości nominalnej słupa z uwzględnieniem warunków gruntowych oraz wyników wykonanych obliczeń lub pomiarów z badań.

Firma Elmonter-Oświetlenie nie ponosi odpowiedzialności za stosowanie fundamentów niezgodnie z ich przeznaczeniem oraz dopuszczalnym obciążeniem (słup + wysięgnik + oprawa), a także w przypadku stosowania innych fundamentów nie spełniających warunków wytrzymałościowych.

Dobór rodzaju i wymiarów fundamentów jest każdorazowo uzależniony od warunków posadawienia, a obowiązek prawidłowego ich doboru, zgodnie z przepisami Prawa Budowlanego, spoczywa na projektancie obiektu.

Elmonter-Lighting's offer includes foundations for the instalation of lighting poles and masts that meet the requirements for strength conditions (maximum fixing moment M that can be applied to the foundation head). The value of the moment M depends on the dimensions of the foundation, the type and properties of the soil in which the foundation is embedded. Calculations of soil load capacity for foundations were made on the basis of PN-80 / B-03322 standard. The presented foundations are made as standard for medium class soil (non-cohesive soil, design angle of internal friction of the soil $\phi=30^\circ$ design calculation density of soil $\gamma_D=17\text{kN/m}^3$. The final selection of foundations is up to the designer after reviewing the ground conditions.

The depth of foundation of the columns directly buried into the ground is specified in the PN-EN 40-2 standard and depends on the nominal height of the column, taking into account ground conditions and the results of calculations or measurements made during tests.

Elmonter-Lighting is not responsible for the use of foundations contrary to their intended use and the permissible load (pole + extension arm + luminaire), as well as in the case of using other foundations that do not meet the strength conditions.

The selection of the type and dimensions of the foundations is each time dependent on the conditions of the foundation and the obligation of their correct selection, in accordance with the provisions of the Construction Law, rests with the designer of the facility.

Na terenie Polski wyróżnia się trzy strefy obciążenia wiatrem:

There are three wind load zones in Poland:

Strefa Zone	Wysokość n.p.m. AMSL – Above Mean Sea Level	V_k [m/s]	q_k [Pa]
I	$H \leq 300$ m	22	300
	$H > 300$ m	$22 \times [1 + 0,0006 \times (H - 300)]$	$300 \times [1 + 0,0006 \times (H - 300)]^2$
II	$H \leq 300$ m	26	420
III	$H \leq 300$ m	22	300
	$H > 300$ m	$22 \times [1 + 0,0006 \times (H - 300)]$	$300 \times [1 + 0,0006 \times (H - 300)]^2 \times [(20000 - H) / (20000 + H)]$

V_k - charakterystyczna prędkość wiatru (dziesięciominutowa prędkość wiatru na wysokości 10 m nad poziomem gruntu w terenie otwartym)
typical wind speed (10-minute wind speed at 10 m above the ground in open area)

q_k - charakterystyczne ciśnienie prędkości wiatru
typical wind pressure

H - wysokość nad poziomem morza
height above sea level

PN-EN 1991-1-4

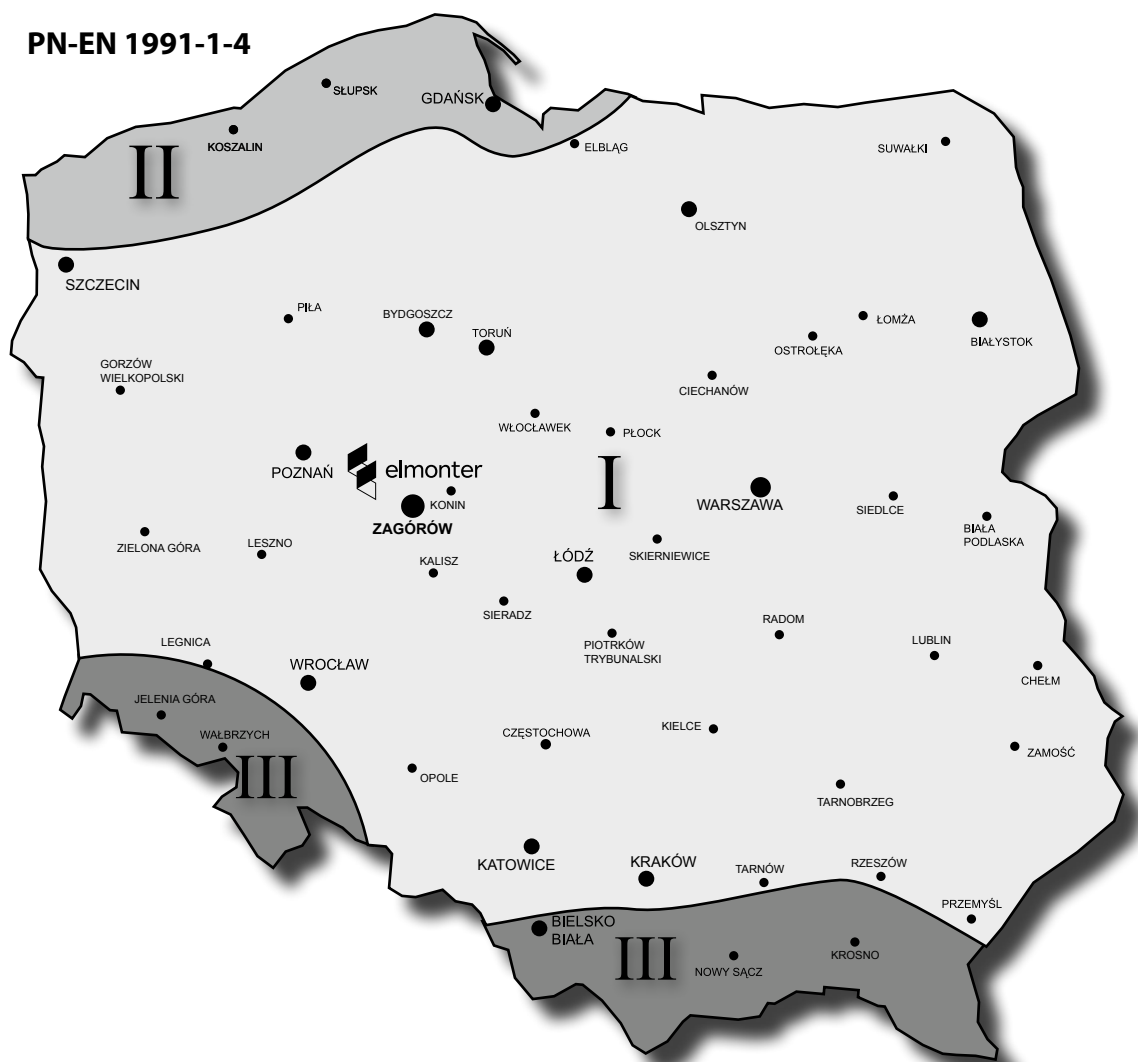

Wszystkie konstrukcje produkowane przez firmę Elmonter-Oświetlenie są cynkowane ogniowo wg normy PN-EN ISO 1461

Producent określa warunki gwarancji w dokumencie ogólne warunki gwarancji oraz ogólne warunki sprzedaży i dostaw, dokumenty dostępne są na stronie www.elmonter.pl

Klient powinien informować producenta o wadach wyrobu, które zostały ujawnione w czasie eksploatacji.

Zgłoszenia reklamacyjne są rozpatrywane w najkrótszym możliwym terminie, jednak nie dłuższym niż 14 dni.

Klient zgłaszający reklamację po dokonaniu oceny technicznej towaru zostanie poinformowany na piśmie o wynikach przeprowadzonej kontroli, a w uzasadnionych przypadkach o sposobie oraz terminie usunięcia wady.

Producent nie ponosi odpowiedzialności za wady, które są wynikiem niewłaściwego użytkowania wyrobu, zmian lub napraw dokonanych we własnym zakresie nie uzgodnionych wcześniej z producentem oraz działania czynników zewnętrznych (np. atmosferycznych), które wcześniej nie zostały ustalone lub nie dały się przewidzieć.

Rozładunek, załadunek powinien się odbywać za pomocą pasów tekstylnych (ograniczona do minimum możliwość zarysowania powłoki cynkowej).

Kupujący odpowiada za poinformowanie producenta o strefie wiatrowej, w której będzie montowany wyrób.

Klient zobowiązuje się do użytkowania wyrobu zgodnie z przeznaczeniem.

Zamawiający, tuż po montażu, dokonuje stosownych napraw ubytków powłoki cynkowej preparatami zawierającymi cynk.

Na życzenie klienta za dodatkową opłatą istnieje możliwość malowania proszkowego cynkowanych elementów, malowania elastomerem oraz systemem antyplakat.

Producent nie ponosi odpowiedzialności za niewłaściwy dobór poszczególnych elementów stanowiących całość konstrukcji.

Charakteryzując ochronę antykorozyjną, jaką jest powłoka cynkowa należy wymienić kilka podstawowych informacji:

- powłoka cynkowa stanowi ochronę konstrukcji przed korozją

- powłoka cynkowa nie jest powłoką ozdobną, w celu uzyskania estetycznego wyglądu produktów zaleca się malowanie powierzchni w odpowiedniej technologii

- powłoka cynkowa w miarę upływu czasu zmienia swój naturalny odcień w wyniku utleniania. Produkty z różnych dostaw mogą różnić się odcieniem warstwy cynkowej jednak po kilku miesiącach (okres ten jest różny i zależy od indywidualnych cech środowiskowych i atmosferycznych danego miejsca) różnice między partiami wyrównują się i przyjmują jednolity odcień

- „biała korozja”, która może pojawić się na ocynkowanych produktach, jest zjawiskiem naturalnym i nie stanowi podstawy reklamacji wg PN-EN ISO 1461. „Biała korozja” nie osłabia ochrony antykorozyjnej produktów. W przypadku wystąpienia „białej korozji” należy zewnętrzną powierzchnię cynkowaną delikatnie oczyścić szczotką drucianą, a w wyniku procesu utleniania powłoka cynkowa powinna ujednolicić swój odcień w przeciągu 3-12 miesięcy. Okres ten jest różny i zależy od indywidualnych cech środowiskowych i atmosferycznych danego miejsca

- powłoka cynkowa nie jest odporna na kwasy o dużym stężeniu, urynę zwierząt oraz niektóre środki chemiczne. Jako dodatkowe zabezpieczenie można zastosować powłokę malarską lub chemiczną (np. polimeryzacja).

Informacje dodatkowe dotyczące produktów, instrukcji, Ogólnych Warunków Sprzedaży i Dostaw oraz gwarancji znajdują się na stronie www.elmonter.pl

All products manufactured by Elmonter-Lighting are hot dip galvanized, in accordance with the PN-EN ISO 1461 norm.

The Manufacturer defines the minimum warranty period as 2 years from the date of sale.

The Client shall inform the Manufacturer about any defects that have emerged during product use.

Complaints shall be handled within the shortest possible time, however not longer than 14 days.

A Client who has filed a complaint shall be informed in writing about the results of the technical assessment/inspection of the product, and – in substantiated cases – about the way and manner of removing the defect.

The Manufacturer shall not be liable for any defects or damages resulting from misuse/misapplication of the product, any changes or repairs performed by the Client – unless previously agreed on with the Manufacturer – and external forces (such as atmospheric conditions) which have not been previously established or could not be predicted.

Loading and unloading should be performed by use of textile conveyor belts (to minimize the risk of scratching the zinc-plated surface).

The Client is obliged to inform the Manufacturer about the wind zone where the product is going to be installed.

The Client undertakes to use the product consistently with its purpose.

Upon the assembly the Client shall repair any zinc coating losses with special zinc-containing preparations.

Upon the Client's request and at additional cost the zinc-plated elements may be powder coated, elastomer coated or antiposter painting system.

The Manufacturer shall not be liable for any damages resulting from improper selection of components.

Characterizing protection against corrosion which is zinc shell it should be indicated few basic information.

- zinc shell constitutes a protection of structures against corrosion.

- zinc shell is not a decorative shell, to obtain an aesthetic appearance of products it is recommended to paint surface in appropriate technology

- zinc shell over time change his natural tone as a result of oxidation. Products from different deliveries may have different tone of zinc shell but after a few months (This period is varied and depends on the individual characteristics of environment and weather conditions of indicated place) the differences between parties will aligned and will adopt a uniform tone.

- "White corrosion" which may appear on galvanized products is a natural phenomenon and doesn't constitute grounds to complaints in accordance to PN-EN ISO 1461, "White corrosion" doesn't weaken corrosion protection of the products. In case of "white corrosion" outside galvanized surface should be gently cleaned with a wire brush and as a result of oxidation zinc surface should unify its tone within 3-12 months. This period is varied and depends on the individual characteristics of environment and weather conditions of indicated place.

- Zinc shell isn't resistant to high concentrations of acids, animal urine and certain chemicals. For additional protection, you can apply a paint coating or chemical (polymerization).

Additional informations regarding products, instructions, terms of sale and delivery and warranty on website www.elmonter.pl



NOTATKI

A series of horizontal dotted lines for writing notes.



elmonter

ul. Przemysłowa 1, 62-410 Zagórow
tel. +48 (63) 274 30 30
www.elmonter.pl